

ÖNDERmak®
ESKİŞEHİR

FIRINDAKİ
GÜCÜNÜZ

SINCE
1976



**Boost
Your
BAKERY**



Hamur İşleme Makineleri ve Fırınlr
Bakery Machines & Ovens
Maquinaria De Panadería Y Hornos

ABOUT US



Foundation

1

1976
Yüksel Kurt
ÖNDER
makina

First product

1976
KYM



Expansion

1977
UZM

3



Expansion

1980

4



New product

1984
FULL SET

5



Alliance

1989
EXPORT

6



Colaboration

1993
INDUSTRIAL LINE
TURKISH OVEN PRODUCERS
M. FORNI
NEW FACTORY

7

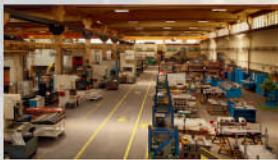

New

1998
ROTOMAT
TYM

8

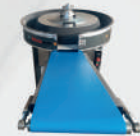

II Generation

2015
LOADER
TECH 4.0
IBA GERMANY

9



2023

2023
Innovation and
Commitment

10





Yüksel KURT
KURUCU BAŞKAN

CHAIRMAN/PRESIDENTE

“KALİTE BİZİM VARLIK SEBEBİMİZ” ,felsefesi ile 1976 yılında başladığım hamur işleme makinaları üretimi yolculuğumda; müşteri odaklı çözüme, nitelikli üretim ve tedarik zincirine, yüksek kalitede satış öncesi – sonrası servise olan bağlılığım, şehrimizle bütünleşen Ondermak Eskişehir adını ayrıcalıklı bir dünya markası olarak taşımış olmam, doğru yolda olduğumuza dair ışık tutmaktadır. Aynı yolda değerli fırıncı dostlarımın Yüksel Usta’sı olarak, onlarla beraber felsefemizden ödün vermeden daha da ileriye gitmeye devam edeceğiz..

““QUALITY IS OUR RAISON D’ÊTRE” depending upon this philosophy from the time I started my journey of manufacturing of dough processing machines; my commitment to customer-oriented solution ,high qualified production and supply chain, primed before/after sales service means that we have been walking on the right path while our company name Ondermak that communed with Eskisehir city becomes among the privileged world brands. As always, I am as their individual solution expert of my baker friends, we will carry on stepping forward on the same road together with them by never compromising on our philosophy.

“CALIDAD, NUESTRA RAZÓN DE SER” dependiendo de esta filosofía desde el momento en el que comencé mi trayecto de la fabricación de máquinas para procesamiento de masa; mi compromiso con la solución orientada al cliente, la producción altamente calificada y la cadena de suministro, anterior/post ventas hacen que llevamos caminando en la ruta de lo mas correcto, mientras que el nombre de nuestra empresa Ondermak que está en comunión con la ciudad de Eskisehir se convierte en una de las marcas mundiales privilegiadas. Siempre, como el experto en las soluciones individuales de mis amigos panaderos, seguiremos avanzando más adelante en el mismo camino junto con ellos sin comprometer nuestra filosofía fundamental

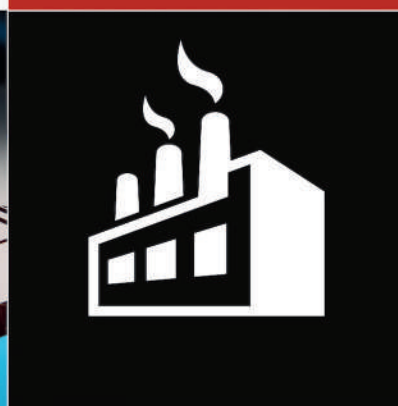

İÇİNDEKİLER

CONTENTS

INDICE



1 - 8

UZUN ŞEKİL VERME MAKİNALARI
LONG MOULDERS
FORMADORAS



9 - 12

KONİK ÇEVİRME MODELLERİ
CONICAL ROUNDERS
BOLEADORAS CONICAS



13 - 18

ARA DİNLENDİRME MAKİNALARI
INTERMEDIATE PROOFERS
CAMARAS DE REPOSO



19 - 24

KESTART - ÇEVİRME
DIVIDERS & ROUNDERS
DIVISORAS Y BOLEADORAS



25 - 28

OTOMATİK DİZME - ROBOT
ROBOTICS & PANNING
CARGADORES Y ROBOTICOS



29 - 36

EKMEK DİLİMLEME
BREAD SLICERS
CORTADORAS DE PAN



37 - 40

SPIRAL VE PLANET MİKSER GRUPLARI
SPIRAL & PLANETARY MIXERS
AMASADORAS ESPIRALES Y BATIDORAS



41 - 41

FIRIN MODELLERİ
OVEN MODELS
MODELOS DE HORNO



UZM SERIES

moulders





UZM 1800

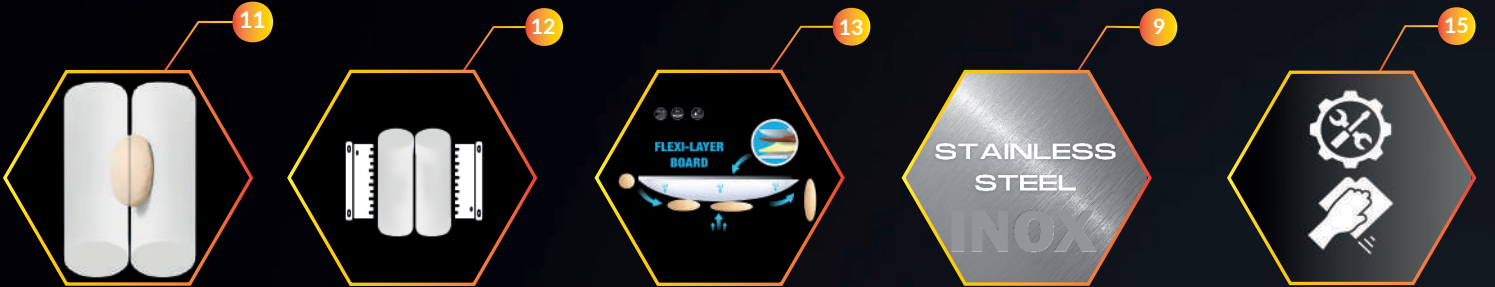
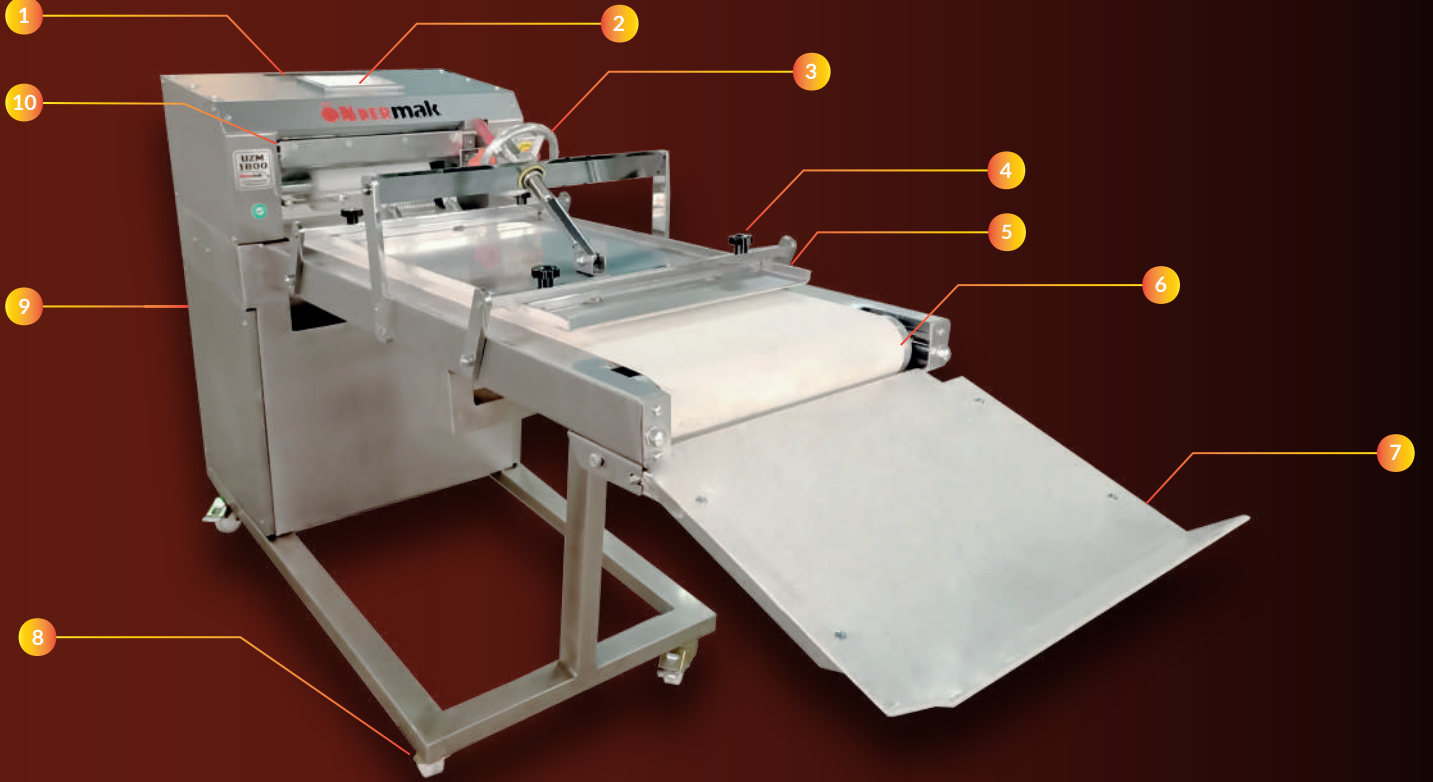

🇹🇷 1 Unlama 2 Hamur Merkezleme 3 Üsten Direksiyon 4 Civatalı Sistem, Kolay Yastık Değişimi 5 1 x "Önder®" Yastık 6 Polyester Hamur Bandı 7 Katlanır Hamur Toplama Standı 8 Frenli Döner Tekerler 9 Tamamı Paslanmaz 10 Ön-Arka El Koruma Paneli 11 2 x Yapışmaz Merdane 12 Ön-Arka Hamur Kazıyıcı 13 Flexi-Layer® Yastıklar 14 Analog Kontrol Paneli 15 Kolay Temizlik - Bakım

🇬🇧 1 flour duster 2 dough centralizer 3 top "volant" type handles 4 bolted joints, easy to replace pressure boards 5 1 x "önder®" pressure boards 6 dough friendly conveyor belt 7 folding dough collector stand 8 swivel wheels with brake 9 entirely stainless steel structure 10 front-back hand protection shield 11 2 x nonstick rollers 12 2 x roller scrapers (front/back) 13 flexi-layer® design pressure boards 14 analogue control panel 15 easy to clean & maintenance

🇪🇸 1 harinadora 2 centralizadora de masa 3 uso tipo "volante" 4 junta atornillada a facil de cambiar tableros 5 1 x tableros de presión 6 cinta transportadora de poliéster 7 plegable recolector de masa 8 ruedas giratorias con frenos 9 estructura completa de inox 10 panel protectivos, plegables (atras/delante) 11 2 x rodillos antiadherentes 12 raspadores de rodillos (atras/delante) 13 flexi-layer® tableros de presión 14 analógico control 15 fácil de limpiar y mantener



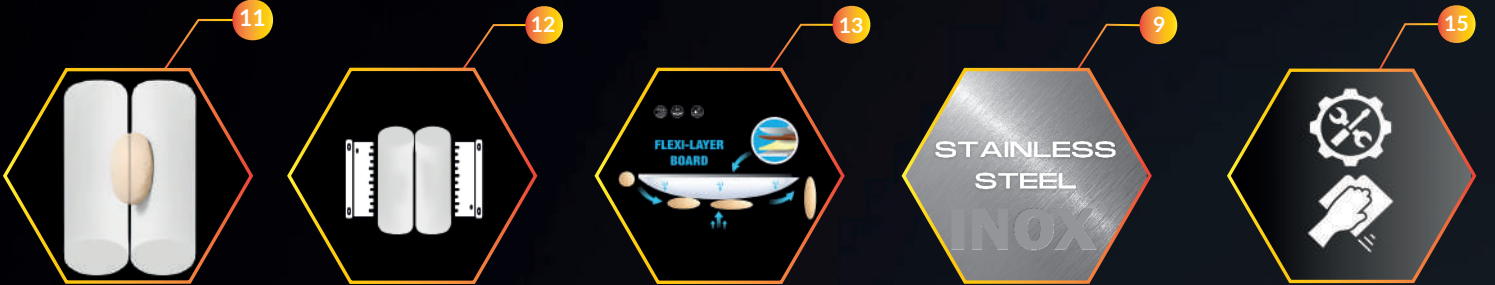
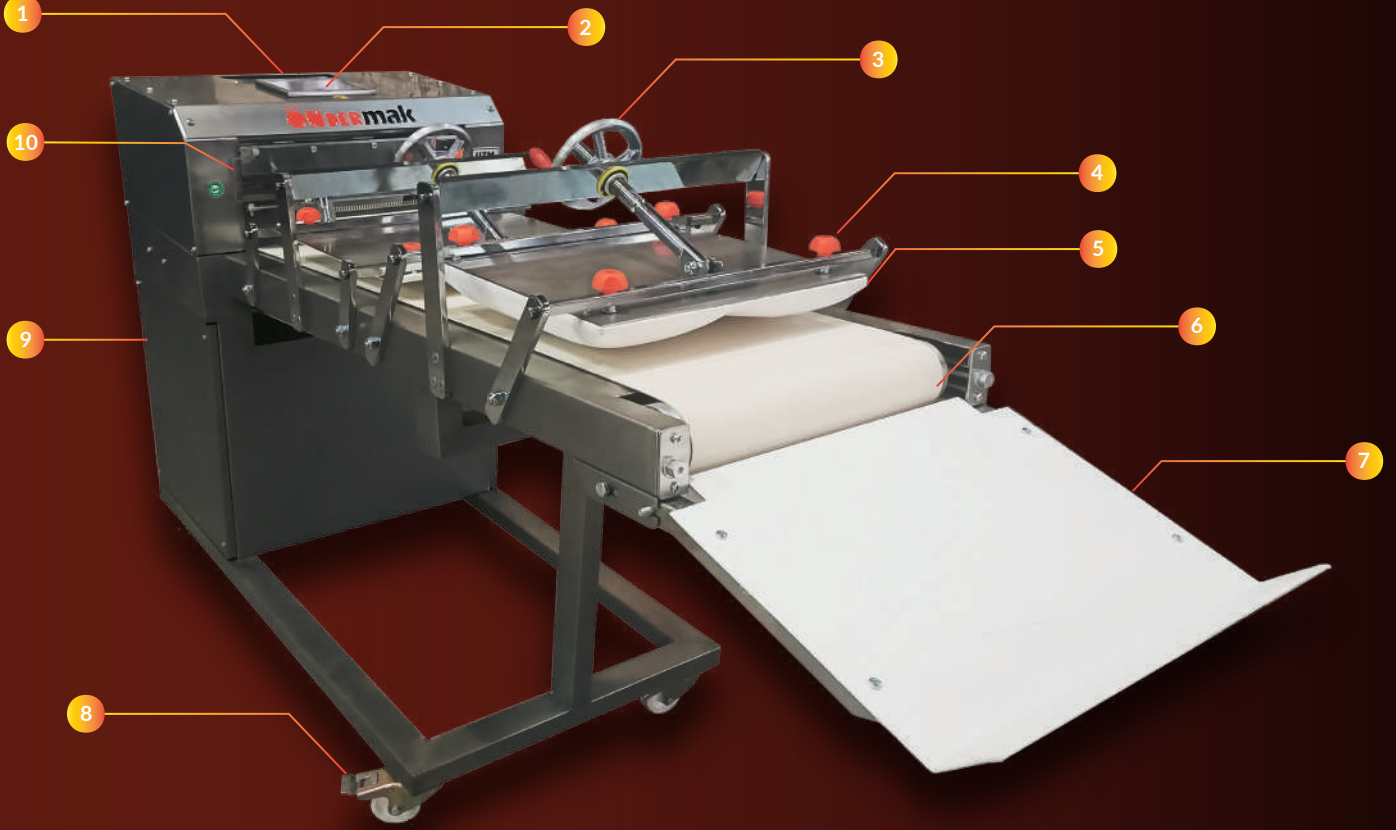

1 Unlama 2 Hamur Merkezleme 3 Üsten Direksiyon 4 Civatalı Sistem, Kolay Yastık Değişimi 5 2 x "Önder®" Yastık 6 Polyester Hamur Bandı 7 Katlanır Hamur Toplama Standı 8 Frenli Döner Tekerler 9 Tamamı Paslanmaz 10 Ön-Arka El Koruma Paneli 11 2 x Yapışmaz Merdane 12 Ön-Arka Hamur Kazıyıcı 13 Flexi-Layer® Yastıklar 14 Analog Kontrol Paneli 15 Kolay Temizlik - Bakım

1 flour duster 2 dough centralizer 3 top "volant" type handles 4 bolted joints, easy to replace pressure boards 5 2 x "önder®" pressure boards 6 dough friendly conveyor belt 7 folding dough collector stand 8 swivel wheels with brake 9 entirely stainless steel structure 10 front-back hand protection shield 11 2 x nonstick rollers 12 2 x roller scrapers (front/back) 13 flexi-layer® design pressure boards 14 analogue control panel 15 easy to clean & maintenance

1 harinadora 2 centralizadora de masa 3 uso tipo "volante" 4 junta atornillada a facil de cambiar tableros 5 2 x tableros de presión 6 cinta transportadora de poliéster 7 plegable recolector de masa 8 ruedas giratorias con frenos 9 estructura completa de inox 10 panel protectivos, plegables (atras/delante) 11 2 x rodillos antiadherentes 12 raspadores de rodillos (atras/delante) 13 flexi-layer® tableros de presión 14 analógico control 15 fácil de limpiar y mantener



Façonneuse - Langroller - Formatrici - Formadora Sodrók - Формовщик - لي وطل اذبخلا ةنكم



1 pousseur de farine 2 centreur de pâte 3 poignée de type « volant » 4 joint boulonné, planche facile à changer 5 2 x planches à pression 6 ceinture en polyester respectueuse de la pâte 7 collecteur de pâte pliable 8 roues pivotantes avec freins 9 structure entièrement en acier inoxydable 10 panneau de sécurité rabattable à l'arrière et à l'avant 11 2 x rouleaux antiadhésifs 12 avant- grattoirs à rouleaux arrière 13 panneaux de pression flexi-layer® 14 panneau de commande analogique 15 facile à nettoyer et à entretenir

1 mehlstreuer 2 teigzentrierer 3 griff vom typ „volant“ 4 verschraubte verbindung, einfach zu wechselndes brett 5 2 x druckbretter 6 teigfreundlicher polyestergürtel 7 faltbarer teigsammler 8 schwenkräder mit bremsen 9 komplett aus edelstahl gefertigte struktur 10 klappbare sicherheitsplatte auf der rückseite 11 2 x antihafbeschichtete rollen 12 rollenabstreifer vorne und hinten 13 flexi-layer® druckplatten 14 analoges bedienfeld 15 einfach zu reinigen und zu warten

1 spolverino 2 centralizzatore impasto 3 maniglia tipo "volant" 4 giunto bullonato, tavola facile da sostituire 5 2 x pannelli pressori 6 nastro in poliester adatto all'impasto 7 raccogli pasta pieghevole 8 ruote girevoli con freni 9 struttura interamente in acciaio inossidabile 10 pannello di sicurezza pieghevole posteriore-anteriore 11 2 x rulli antiaderenti 12 anteriore- rullo posteriore raschiatori 13 pannelli a pressione flexi-layer® 14 pannello di controllo analogico 15 facile da pulire e manuteneere

1 espanador de farinha 2 centralizador de massa 3 alça tipo "volante" 4 junta aparafusada, placa fácil de trocar 5 2 x placas de pressão 6 correia de poliéster amigável para massa 7 coletor de massa dobrável 8 rodas giratórias com freios 9 estrutura totalmente em aço inoxidável 10 painel de segurança dobrável traseiro-frontal 11 2 x rolos antiaderentes 12 frente- rolo traseiro raspadores 13 placas de pressão flexi-layer® 14 painel de controle analógico 15 fácil de limpar e manter

1 lisztporoló 2 tészta központósító 3 volant típusú fogantyú 4 csavarozott csatlakozás, könnyen cserélhető tábla 5 2 x nyomólap 6 tésztabarát poliészter szalag 7 összehajtható tésztagyűjtő 8 forgó kerekek 9 forgó kerekek, feszítőkerek nélkül, feszített fékekkel 11 2 x tapadásmentes görgő 12 előlő-hátsó görgő lehúzó 13 flexi-layer® nyomólapok 14 analóg vezérlőpanel 15 könnyen tisztítható és karbantartható

1 Мучная насадка 2 Центратор теста 3 Ручка типа «Volant» 4 Болтовое соединение, легко заменяемая доска 5 2 прижимные доски 6 Полиэстеровая лента, подходящая для теста 7 Складной тестосборник 8 Поворотные колеса с тормозами 9 Полностью конструкция из нержавеющей стали 10 Складная защитная панель сзади 11 2 ролика с антипригарным покрытием 12 Передне-задний валик 13 Скрепки 14 Планы давления Flexi-Layer® 15 Аналоговая панель управления 15 Легко чистить и обслуживать

1 نيج غلل قيديص رتس لوب مازح 2 طغض حاولاً × 2 3 ري غتلا لس حول ري ماس مب لصفم 4 "Volant" عونلا نم ضبقم 5 نيج عل زكرم 6 قيديدل افضنم 7 نيج غلل قيديص رتس لوب مازح 8 طغض حاولاً × 2 9 ري غتلا لس حول ري ماس مب لصفم 10 لام الكلاب اذصللل مواقملا ذالوفلا نم لكيه 11 لام ارف عم قراود تالاج ع 12 يطلل لباق نيج ع 13 قن اصيل او فيظن تلتا لس 14 فيرطان ت مكحت ةحول 15 طغض تاحول Flexi-Layer® 16 تااطشاك



1800 pcs/hr



50 - 650

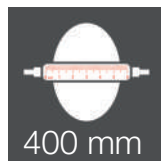

400 mm

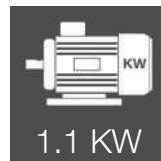

1.1 KW



400V
3NPE 50/60 hz

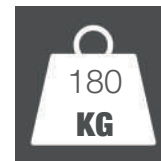

180
KG



2 YEARS
WARRANTY



ANALOG

	640 mm
	2030 mm
	1125 mm

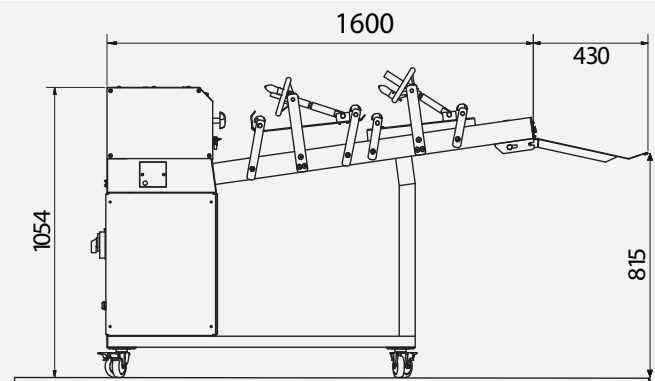
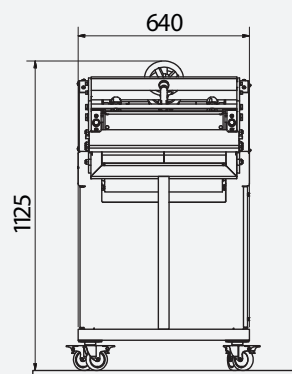



HZM 2000

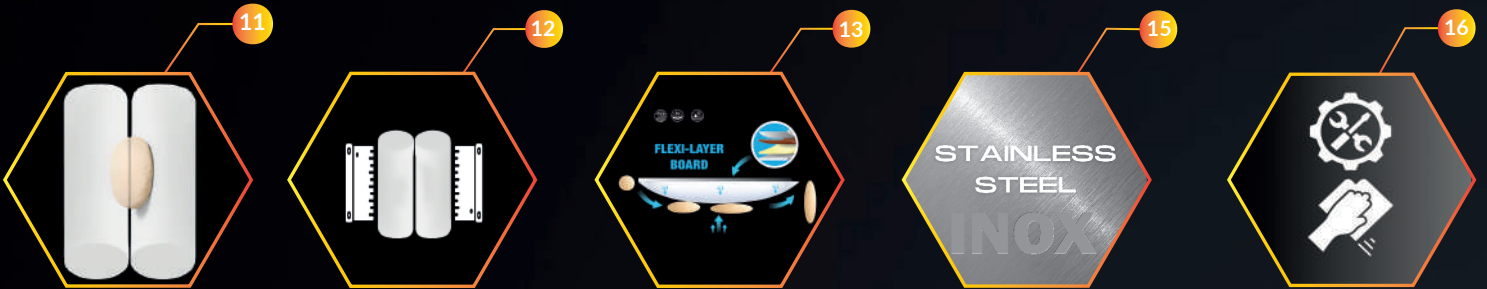
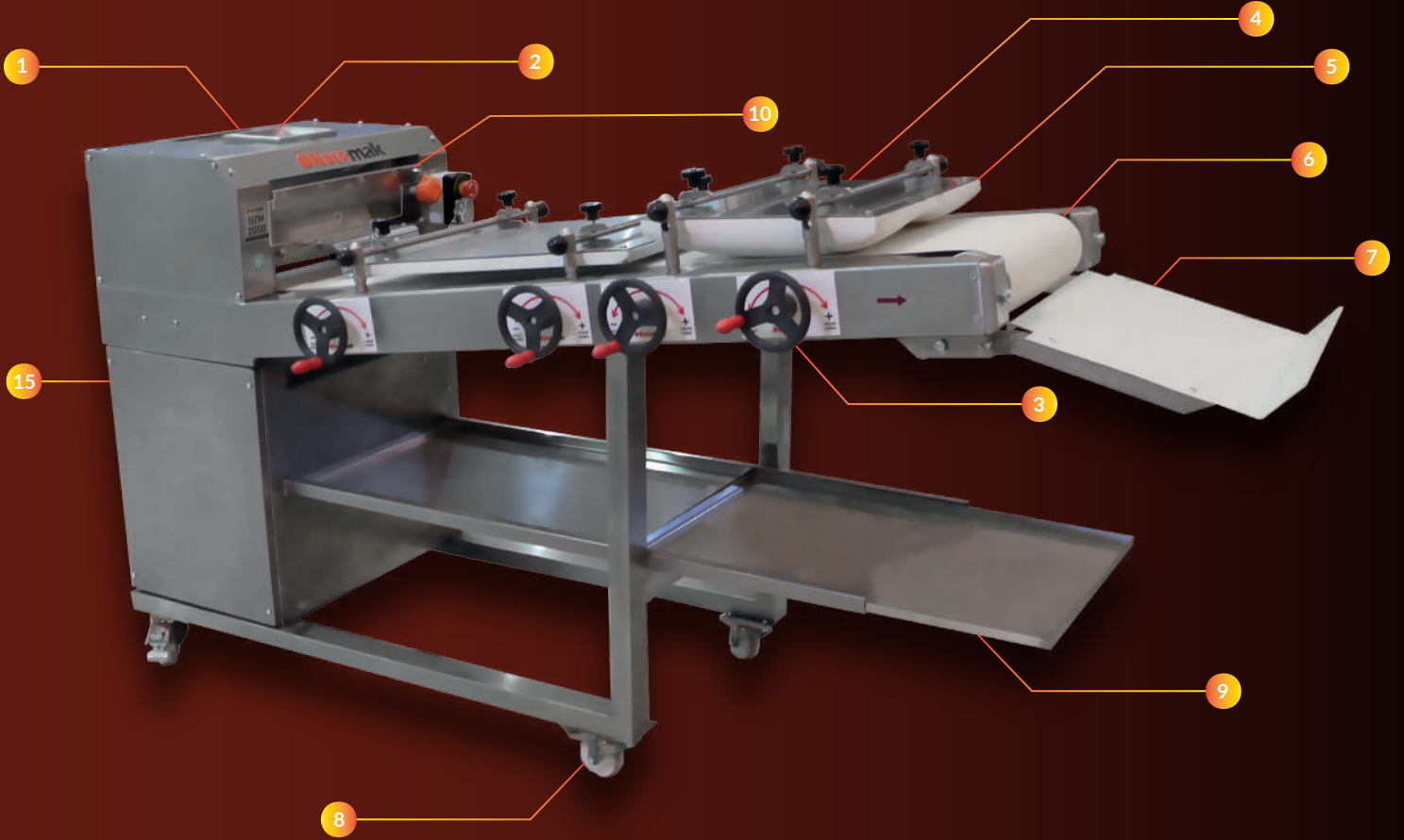

🇹🇷 **1**Unlama **2**Hamur Merkezleme **3**Yandan Ayarlı Direksiyon , Sağ Sol Bağımsız Ayarlama – Hassas Yatık Ayarı **4**Civatalı Sistem, Kolay Yastık Değişimi **5**2 x “Önder®” Yastık **6**Polyester Hamur Bandı **7**Katlanır Hamur Toplama Standı **8**Frenli Döner Tekerler **9**Paslanmaz Hareketli Tepsi **10**Ön-Arka El Koruma Paneli **11**2 x Yapışmaz Merdane **12**Ön-Arka Hamur Kazıyıcı **13**Flexi-Layer® Yastıklar **14**Analog Kontrol Paneli **15**Tamamı Paslanmaz **16**Kolay Temizlik - Bakım

🇬🇧 **1** flour cluster **2** dough centralizer **3** independent left and right rear handles , easy fine tuning **4** bolted joints, easy to replace pressure boards **5** 2 x “önder®” pressure boards **6** dough friendly conveyor belt **7** folding dough collector stand **8** swivel wheels with brake **9** 2 x stainless steel tray with slides **10** front-back hand protection shield **11** 2 x nonstick rollers **12** 2 x roller scrapers (front/back) **13** flexi-layer® design pressure boards **14** analogue control panel **15** entirely stainless steel structure **16** easy to clean & maintenance

🇪🇸 **1**harinadora **2**centralizadora de masa **3**independientes volantes traseros (izquierda/derecha), facilidad en ajuste fino **4** junta atornillada a facil de cambiar tableros **5**2 x tableros de presión **6**cinta transportadora de poliéster **7**plegable recolector de masa **8**ruedas giratorias con frenos **9**2 x bandejas de inox con correderas **10**panel protectivos, plegables (atras/delante) **11**2 x rodillos antiadherentes **12**raspadores de rodillos (atras/delante) **13**flexi-layer® tableros de presión **14**analógico control **15**estructura completa de inox **16**fácil de limpiar y mantener





ÖZM 4800

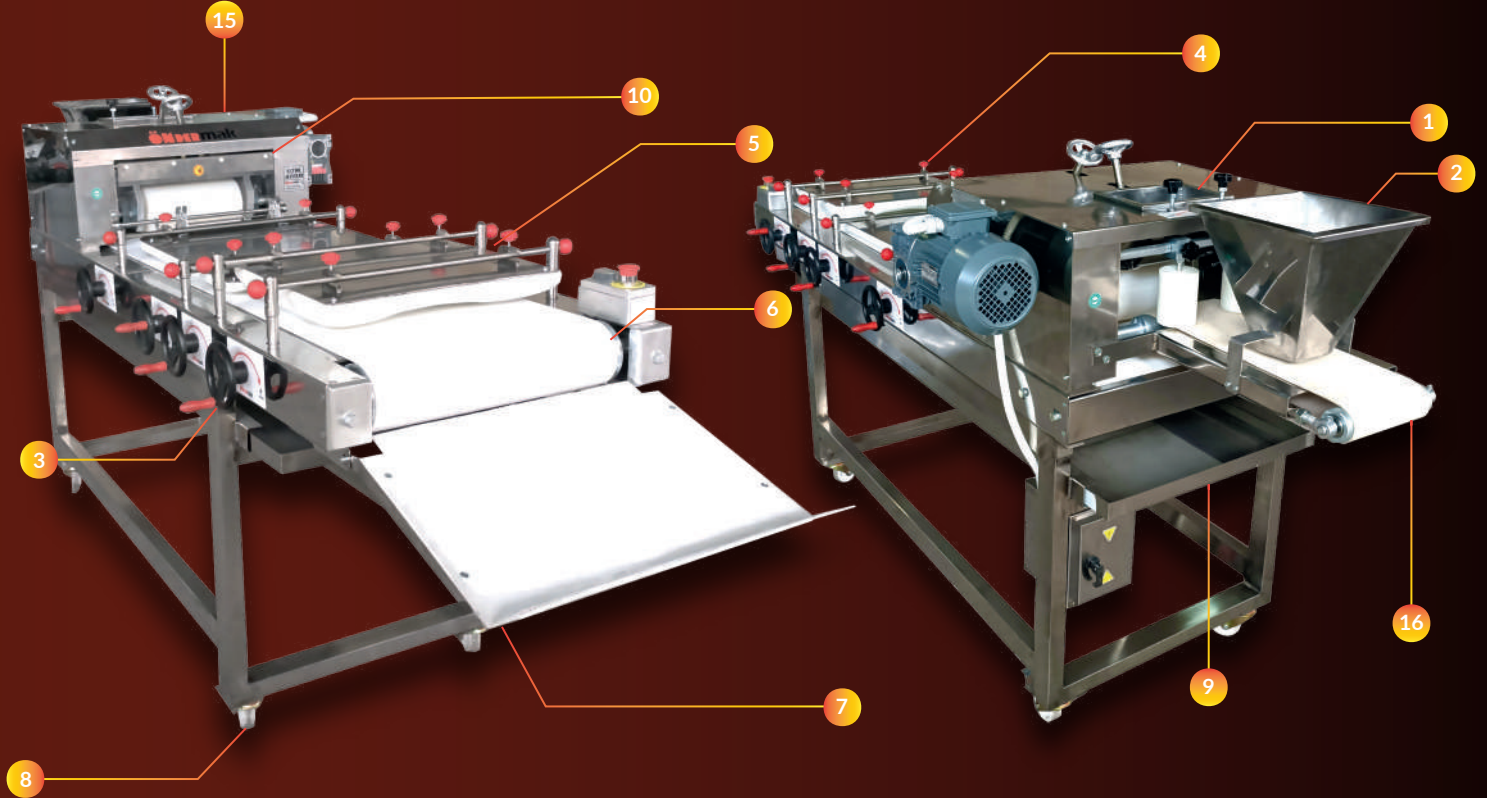

🇹🇷 1 Unlama 2 Pro Hamur Merkezleme 3 Yandan Ayarlı Direksiyon , Sağ Sol Bağımsız Ayarlama – Hassas Yatık Ayarı 4 Cıvatalı Sistem, Kolay Yastık Değişimi 5 2 x “Önder®” Yastık 6 Polyester Hamur Bandı 7 Katlanır Hamur Toplama Standı 8 Frenli Döner Tekerler 9 Paslanmaz Hareketli Tepsi 10 Ön-Arka El Koruma Paneli 11 2 x Yapışmaz Mardane 12 Band İle Mardane Arasında Hamur Açma Becerisi 13 Flexi-Layer® Yastıklar 14 Analog Kontrol Paneli 15 Tamamı Paslanmaz 16 Konveyör Giriş Bandı 17 Kolay Temizlik - Bakım

🇬🇧 1 flour duster 2 professional dough centralizer 3 independent left and right rear handles , easy fine tuning 4 bolted joints, easy to replace pressure boards 5 2 x “önder®” pressure boards 6 dough friendly conveyor belt 7 folding dough collector stand 8 swivel wheels with brake 9 2 x stainless steel tray with slides 10 front-back hand protection shield 11 2 x nonstick rollers 12 direct dough lamination between rollers and belt: hydrated dough without loss, the best artisan bread form, suitable for all type of bread and dough 13 flexi-layer® design pressure boards 14 analogue control panel 15 entirely stainless steel structure 16 motorized dough feeding belt 17 easy to clean & maintenance

🇪🇸 1 harinadora 2 profesional centralizadora de masa 3 independientes volantes traseros (izquierda/derecha), facilidad en ajuste fino 4 junta atornillada a facil de cambiar tableros 5 2 x tableros de presión 6 cinta transportadora de poliéster 7 plegable recolector de masa 8 ruedas giratorias con frenos 9 2 x bandejas de inox con correderas 10 panel protectivos, plegables (atras/delante) 11 2 x rodillos antiadherentes 12 laminación directa de la masa entre rodillos y cinta: masa hidratada sin pérdidas, la mejor forma de pan artesano, apta para todo tipo de panes y masas 13 flexi-layer® tableros de presión 14 analógico control 15 estructura completa de inox 16 cinta motorizada para alimentar masa 17 fácil de limpiar y mantener



Façonneuse - Langroller - Formatrici - Formadora Sodrók - Формовщик - لي و ط ل ا ز ب خ ل ا ة ن ك م



1 pousseur de farine **2** professionnel centreur de pâte **3** poignées arrière gauche et droite indépendantes, réglage fin facile **4** joint boulonné, planche facile à changer **5** 2 x plaques à pression **6** ceinture en polyester respectueuse de la pâte **7** collecteur de pâte pliable **8** roues pivotantes avec freins **9** 2x plateau en acier inoxydable avec glissières **10** panneau de sécurité rabattable à l'arrière et à l'avant **11** 2 x rouleaux antiadhésifs **12** stratification directe de la pâte entre les rouleaux et la bande:pâte hydratée sans perte, la meilleure forme de pain artisanal, adaptée à tout type de pain et de pâte **13** panneaux de pression flexi-layer® **14** panneau de commande analogique **15** structure entièrement en acier inoxydable **16** tapis motorisé d'alimentation en pâte **17** facile à nettoyer et à entretenir

1 mehlmstreuer **2** fachmann teigzentrierer **3** unabhängige linke und rechte hintere griffe, einfache feinabstimmung **4** verschraubte verbindung, einfach zu wechselndes brett **5** 2 x druckbretter **6** teigfreundlicher polyestergürtel **7** faltbarer teigsammler **8** schwenkräder mit bremsen **9** 2 x edelstahlblett mit rutschen **10** klappbare sicherheitsplatte auf der rückseite **11** 2 x antihaftbeschichtete rollen **12** direkte teiglaminiierung zwischen walzen und band: hydratisierter teig ohne verlust, die beste handwerklich hergestellte brotform, geeignet für alle brot- und teigarten **13** flexi-layer® druckplatten **14** analoges bedienfeld **15** komplett aus edelstahl gefertigte struktur **16** motorisiertes teigzuführband **17** einfach zu reinigen und zu warten

1 spolverino **2** professionale centralizzatore impasto **3** maniglie posteriori indipendenti sinistra e destra, facile regolazione fine **4** giunto bullonato, tavola facile da sostituire **5** 2 x pannelli pressori **6** nastro in poliestere adatto all'impasto **7** raccogli pasta pieghevole **8** ruote girevoli con freni **9** 2 x vassoi in acciaio inossidabile con scivoli **10** pannello di sicurezza pieghevole posteriore-anteriore **11** 2 x rulli antiaderenti **12** laminazione diretta dell'impasto tra rulli e nastro: impasto idratato senza perdite, la migliore forma di pane artigianale, adatto a tutti i tipi di pane e impasto **13** pannelli a pressione flexi-layer® **14** pannello di controllo analogico **15** struttura interamente in acciaio inossidabile **16** motorizzato nastro alimentazione impasto **17** facile da pulire e manuteneere

1 espanador de farinha **2** profissional centralizador de massa **3** alças traseiras esquerda e direita independentes, fácil ajuste fino **4** junta aparafusada, placa fácil de trocar **5** 2 x placas de pressão **6** correia de poliéster amigável para massa **7** coletor de massa dobrável **8** rodas giratórias com freios **9** 2 x bandeja de aço inoxidável com corrediças **10** painel de segurança dobrável traseiro-frontal **11** 2 x rolos antiaderentes **12** laminação direta de massa entre rolos e esteira: massa hidratada sem perdas, a melhor forma de pão artesanal, adequada para todos os tipos de pães e massas **13** placas de pressão flexi-layer® **14** painel de controle analógico **15** estrutura totalmente em aço inoxidável **16** correia motorizada de alimentação de massa **17** fácil de limpar e manter

1 lisztporoló **2** szakmai téstacentrál **3** független bal és jobb hátsó fogantyúk, könnyű finombeállítás **4** csavarral rögzített illesztések, könnyen cserélhető nyomóeszkák **5** 2 x önder® nyomólap **6** téstatabarát szállítószalag **7** összecusukható téstagyűjtő állvány **8** forgó kerekék fékkel **9** 2 x rozsdamentes acél tálcá csúszdákkal **10** első hátsó kézzel védő pajzs **11** 2 x tapadásmentes görgők **12** közvetlen téstá laminálás a hengerek és az őv között: hidratált téstá veszteség nélkül, a legjobb kézműves kenyérforma, minden típusú kenyérhez és téstához alkalmas **13** flexi-layer® design nyomólapok **14** analóg kezelőpanel **15** teljesen rozsdamentes acél szerkezet **16** motoros téstá adagoló szalag **17** könnyen tisztítható és karbantartható

1 Мучная насадка **2** Центратор теста Профессиональный **3** Независимые левая и правая задние ручки, простая точная настройка **4** Болтовое соединение, легко заменяемая доска **5** 2 прижимные доски **6** Полиэстеровая лента, подходящая для теста **7** Складной тестосборник **8** Поворотные колеса с тормозами **9** 2 подноса из нержавеющей стали с направляющими **10** Складная защитная панель сзади **11** 2 ролика с антипригарным покрытием **12** Прямое ламинирование теста между валками и лентой: гидратированное тесто без потерь, лучшая форма домашнего хлеба, подходящая для всех типов хлеба и теста **13** Планы давления Flexi-Layer® **14** Аналоговая панель управления **15** Полностью конструкция из нержавеющей стали **16** Моторизованная лента подачи теста **17** Легко чистить и обслуживать

قيدص رتس يلوب مازح **6** طغض حاول $\times 2$ **5** ري ري غتلا لس حول ، ري ماس ب لسفم **4** لس ق ي ق يد طبض ، ل ق تسم ن ي م راس ي ة يفل خ ض باق م **3** ي فار ت ا ح ن ي ج خ ل ا ز ك ر م **2** ق ي ق د ل ا ق ض ف ن م **1** ن ي ج خ ل ا ح ي ف ص ت **12** ق ق ص ا ل ر ي غ ت ا ر ك ب $\times 2$ **11** ف ل خ ل ا و م ا م ا ل ن م ي ط ل ل ل ب ا ق ن ا م ا ة ح و ل **10** ح ي ا ر ش ع م ا د ص ل ل م و ا ق م ل ا ذ ا ل و ف ل ا ن م ن ي ن ي ص $\times 2$ **9** ل م ا ر ف ع م ق ر ا و د ت ا ل ج ع **8** ي ط ل ل ل ب ا ق ن ي ج ع ع م ا ج **7** ن ي ج خ ل ا م و ا ق م ل ا ذ ا ل و ف ل ا ن م ل ك ي **15** ة ي ر ط ا ن ت م ك ح ت ح و ل **14** ط غ ض ت ا ح و ل **13** Flexi-Layer® ن ي ج خ ل ا و ز ب خ ل ا ع ا و ن ا ع ي م ج ل ب س ا ن م ، ي ف ر ح ز ب خ ل ك ش ل ض ف ا ، ن ا د ق ف ن و د ق ب ط ر ن ي ج ع : م ا ز ح ل ا و ت ا ر ك ب ل ا ن ي ب ر ش ا ب م ل ا ة ن ا ي ص ل ا و ف ي ظ ن ت ل ا ل م س **17** ل ك ر ح ب ن ي ج خ ل ا ق ي ذ غ ت م ا ز ح **16** ل م ا ف ل ا ب ا د ص ل ل



6500 pcs/hr



50 - 1200



450 mm

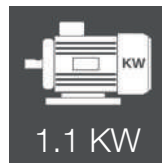

1.1 KW



400V
3NPE 50/60 hz



300
KG



2 YEARS
WARRANTY



ANALOG

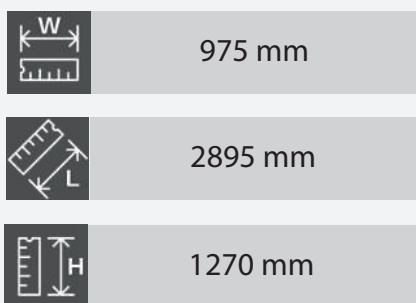

975 mm

2895 mm

1270 mm

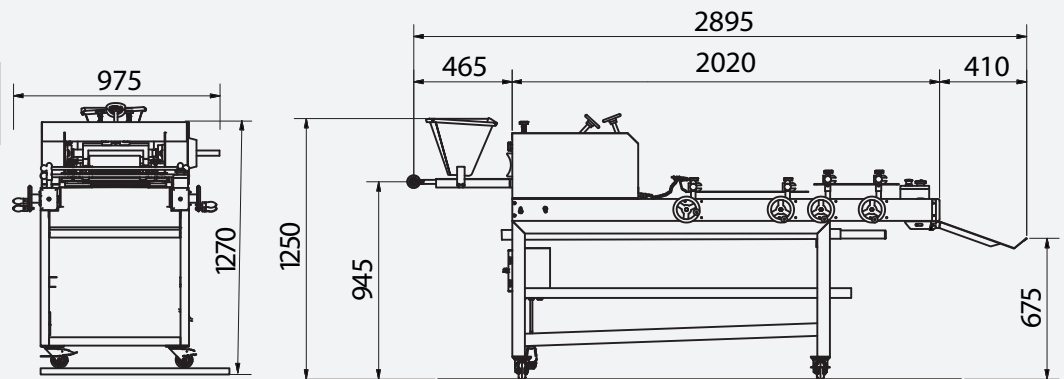

Konveyör - Conveyor - Transportadora
 Convoyeur - Förderer - Trasportatore - Transportador
 Szállítószalag - Конвейер - لقانال

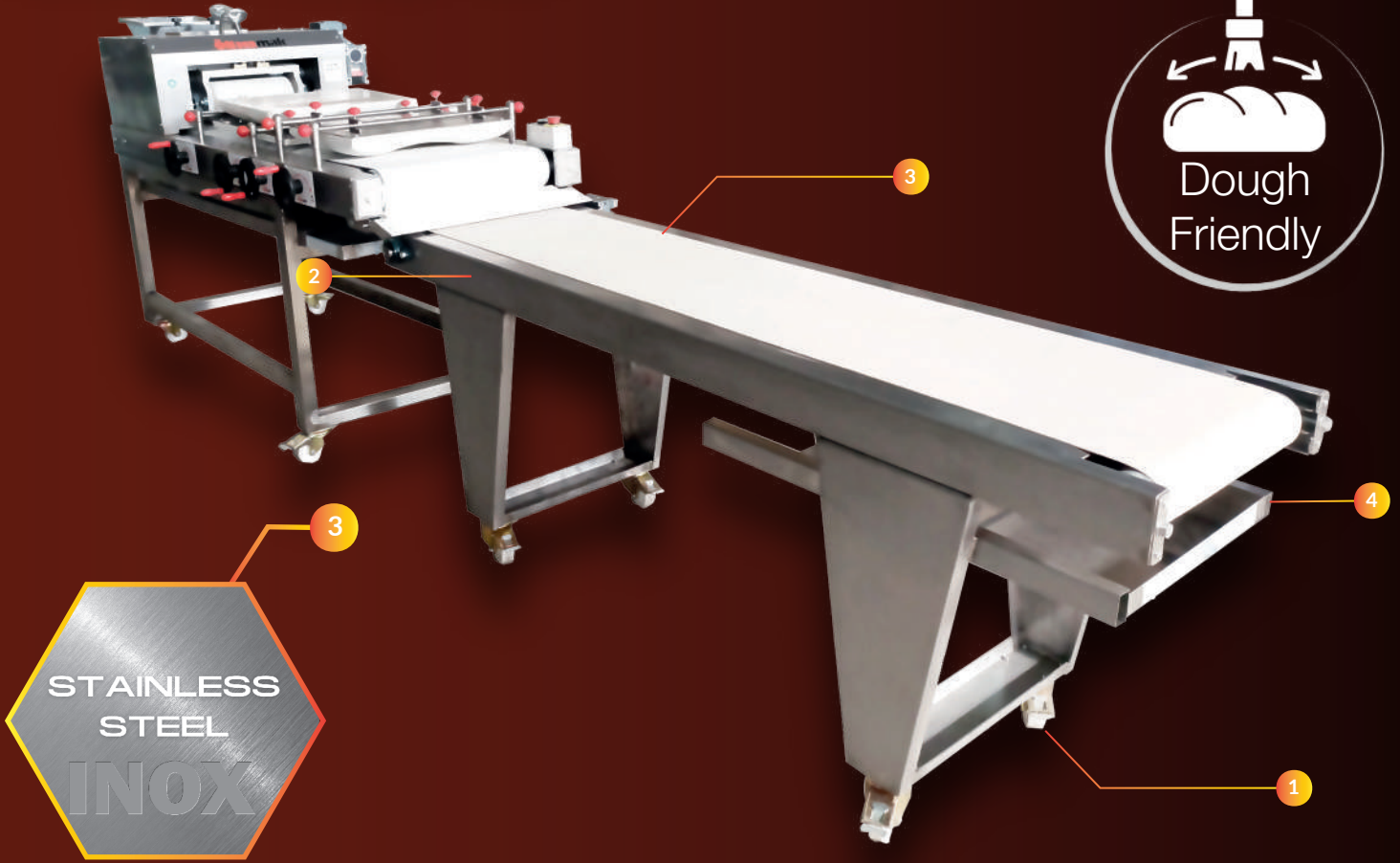

- 1 Harici,seyyar hamur taşıma konveyörü/External mobil dough conveyor / Móvil externo transportador de masa / Mobile externe convoyeur de pâte / Externer mobiler teigförderer / Mobile esterno Trasportatore pasta / Móvel externo transportador de massa / Külső mobil tézstaszállító / Внешний мобильный конвейер теста / يجرأخ لىبوم نىج ع لقان /
- 2 Tamamı paslanmaz çase / Entirely stainless steel structure / Estructura completa de INOX / Structure entièrement en acier inoxydable / Komplet aus edelstahl gefertigte struktur / Struttura interamente in acciaio inox/Estrutura totalmenteem aço inoxidável / Teljesen rozsdamentes acél szerkezet / Полностью конструкция из нержавеющей стали / أدصلل مواقلل ذالوفلا نم لكىه /
- 3 Polyester ya da PVC taşıma bandı / Conveyor belt made of polyester or PVC / Cinta transportadora de poliéster o PVC / Bande transporteuse en polyester ou PVC / Förderband aus Polyester oder PVC/ Nastro trasportatore in poliestere o PVC / Correia transportadora em poliéster ou PVC / Szállítószalag poliészterből vagy PVC-ből / Конвейерная лента из полиэстера или ПВХ. / وأرئس يلوبلا نم عونصم لقانلال مازحلا /
- 4 Paslanmaz hamur tepsi/ Stainless steel recycle tray / Bandeja de reciclaje de INOX / Bac de recyclage en acier inoxydable / Recyclingschale aus edelstahl / Vassoio per il riciclaggio in acciaio inossidabile / Bandeja de reciclagem de aço inoxidável / Rozsdamentes acél újrahaznosító tálcá/ Лоток для мусора из нержавеющей стали / أدصلل مواقلل ذالوفلا نم رىودئلال ءداع! ءىننىص /

	400 - 2000 mm
	1000 - 4000 mm
	Max.4000 mm

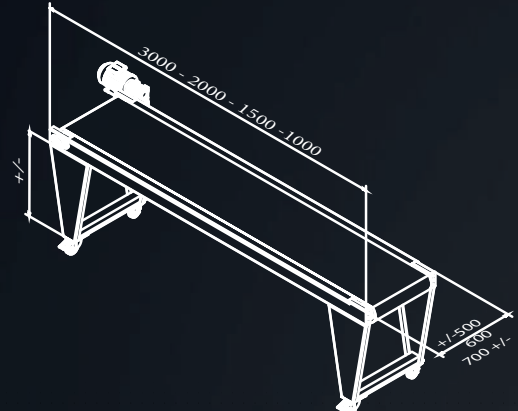
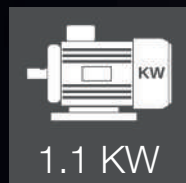



KYM SERIES

rounders

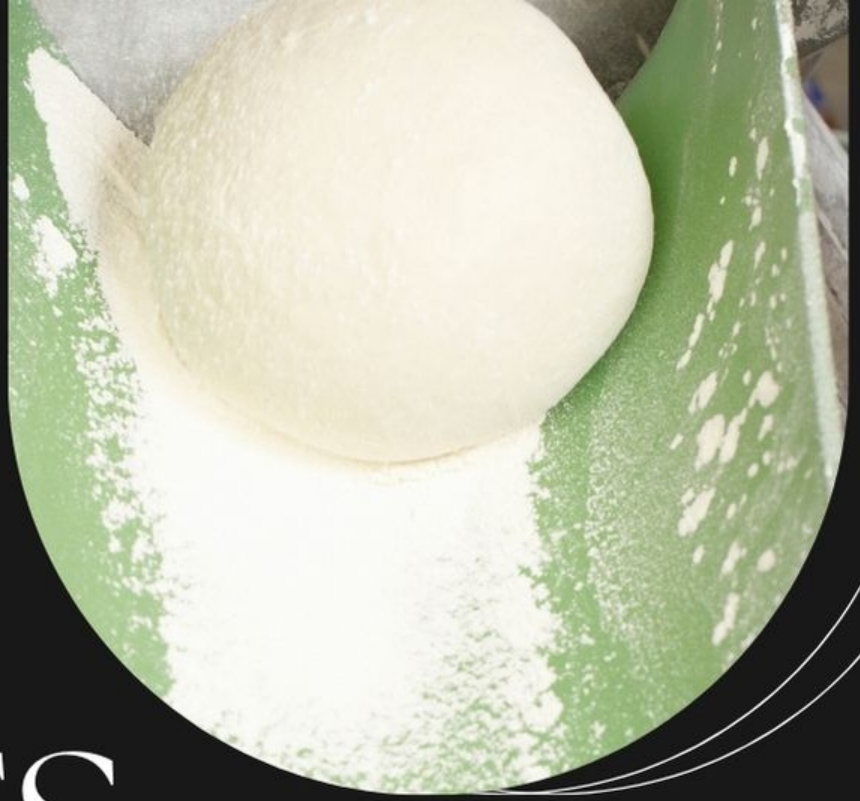



KYM SERIES



TEFLON

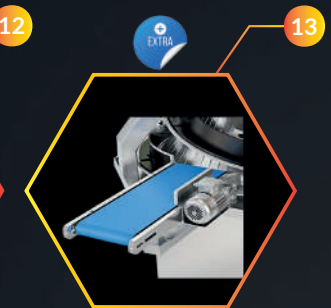
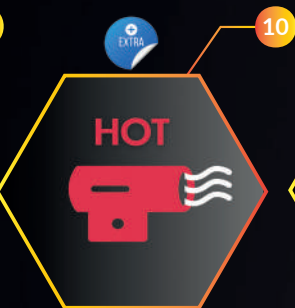
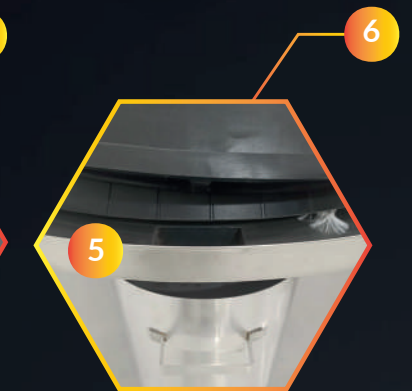



- 1 Ön-Arka Ayarlanır Unlama 2 Alüminyum Döküm Helezon ve Huni 3 Önder® Tasarım Sabit Helezon 4 Soğuk Hava Üfleme 5 Un Toplama Kovası 6 Huni Altı Temizleme Fırçası 7 Her Hamur İçin Farklı Helezon Uzunluğu 8 Frenli Döner Tekerler 9 Teflon Helezon ve Huni Kaplama(+) 10 Sıcak Hava(+) 11 Hız Kontrol Cihazı(+) 12 Yağlama Ünitesi(+) 13 Çıkış Bandı(+) 14 Analog Kontrol Paneli 15 Tamamı Paslanmaz 16 Kolay Temizlik - Bakım

- 1 front-back adjustable flour duster 2 aluminum cast cone & tracks 3 önder® design fixed tracks 4 cool air blower 5 flour recycle bin 6 bottom cone flour sweeper 7 variable track design & length according to dough 8 swivel wheels with brake 9 teflon coated cone & tracks(+) 10 hot air blower(+) 11 speed control(+) 12 mechanical oil spraying unit(+) 13 output feeding conveyor(+) 14 analogue control panel 15 entirely stainless steel structure 16 easy to clean & maintenance

- 1 detrás/delantero enharinador 2 cono y canales de aluminio fundido 3 önder® diseño, canales fijados 4 soprador de aire fresco 5 cubo para reciclar harina 6 cepillo a limpiar debajo de cono 7 canales variables en diseño y longitudes según masa 8 ruedas giratorias con frenos 9 cono y canales teflonados antiadherentes(+) 10 soprador de aire caliente(+) 11 variador de velocidad(*) 12 mecánico rociador de aceite(+) 13 cinta transportadora a la salida(+) 14 analógico control 15 estructura completa de inox 16 fácil de limpiar y mantener

- 1 malaxeur arrière/avant 2 cône et canaux en aluminium moulé 3 önder® conception, canaux fixés 4 souffleur d'air frais 5 bac de recyclage de la farine 6 brosse pour nettoyer sous le cône 7 canaux de conception variable et longueurs selon la pâte 8 roues pivotantes avec freins 9 cône et canaux antiadhésifs en teflon(+) 10 souffleur d'air chaud(*) 11 variateur de vitesse(+) 12 vaporisateur d'huile mécanique(+) 13 convoyeur à la sortie(+) 14 panneau de commande analogique 15 structure entièrement en acier inoxydable 16 facile à nettoyer et à entretenir

- 1 vorne-hinten verstellbarer mehl-streuer 2 aluminium-gusskegel und spuren 3 önder® design feste spuren 4 kühlluftgebläse 5 mehl-recycling-behälter 6 bodenkegel mehlsammler 7 variable spur-design und länge entsprechend dem teig 8 schwenkräder mit bremse 9 teflonbeschichteter kegel und spuren(+) 10 heißluftgebläse(+) 11 geschwindigkeitsregelung(+) 12 mechanische ölsprühvorrichtung(+) 13 auslauf-förderband(+) 14 analoges bedienfeld 15 vollständig edelstahl-struktur 16 leicht zu reinigen und zu warten

- 1 retro/fronte impastatrice 2 cono e canali in alluminio fuso 3 önder® design, canali fissati 4 soffiatore d'aria fresca 5 contenitore per riciclare farina 6 spazzola per pulire sotto al cono 7 canali variabili nel design e lunghezze in base all'impasto 8 ruote girevoli con freni 9 cono e canali teflonati antiaderenti(+) 10 soffiatore d'aria calda(+) 11 variatore di velocità(+) 12 spruzzatore meccanico di olio(+) 13 nastro trasportatore in uscita(+) 14 pannello di controllo analogico 15 struttura interamente in acciaio inossidabile 16 facile da pulire e manutene

- 1 polvilhador traseiro/dianteiro 2 cone e canais de alumínio fundido 3 design önder®, canais fixos 4 soprador de ar fresco 5 recipiente para reciclagem de farinha 6 escova para limpeza sob o cone 7 canais variáveis em design e comprimentos de acordo com a massa 8 rodízios giratórios com freios 9 cone e canais revestidos com teflon antiaderente(+) 10 soprador de ar quente(+) 11 variador de velocidade(+) 12 pulverizador mecânico de óleo(+) 13 fita transportadora na saída(+) 14 controle analógico 15 estrutura completa de aço inox 16 fácil de limpar e manter

- 1 Elő-Hátul Állítható Lisztszóró 2 Alumínium Öntött Tölcsér És Sín 3 Önder® Design Fix Sín 4 Hideg Levegő Fúvó 5 Liszt Újrafelhasználó Tartály 6 Alsó Tölcsér Lisztsöpő 7 Változó Síntervezés És Hossz A Tésztához Igazítva 8 Forgó Kerekek Fékkel 9 Teflon Bevonatú Tölcsér És Sínek(+) 10 Meleg Levegőfúvó(+) 11 Sebességvezérlés(+) 12 Mechanikus Olajpermetező Egység(+) 13 Kimeneti Adagolószalag(+) 14 Analóg Vezérlőpanel 15 Teljesen Rozsdamentes Acél Szerkezet 16 Könnyen Tisztítható És Karbantartható

- 1 Насадка для муки с регулируемым положением спереди и сзади 2 Алюминиевый литой конус и дорожки 3 Фиксированные дорожки с дизайном Önder® 4 Вентилятор холодного воздуха 5 Контейнер для переработки муки 6 Щетка для муки на нижнем конусе 7 Дизайн переменной длины и дорожек в соответствии с тестом 8 Поворотные колеса с тормозом 9 Конус и дорожки с покрытием тефлоном(+) 10 Вентилятор горячего воздуха(+) 11 Регулировка скорости(+) 12 Механический блок для распыления масла(+) 13 Транспортёр для выдачи продукции(+) 14 Аналоговая панель управления 15 Структура полностью из нержавеющей стали 16 Легко моется и обслуживается

- 1 نيج حطلا ريودت ةنيك ام 2 درابلا ءاولا خافنم 3 تتبائل تاراسم لىل Önder® ميمصت 4 تاراسم موينم آل نم بوبصم نوک 5 فلخل او مامل ةن حطما قنم مظنم 6 نينخاسلا ءاولا خافنم 7 نولفتل اب فلغم 8 لمارف عم قراود تالاجع 9 نيجخلل افسو لوطو ريغتم راسم ميمصت 10 ةي طورخما ةيلفسلا نيجحلا قسنم 11 لمالكاب اذصلل مواقما ذالوفلا نم لكيه 12 ةيرظانت مكحت حول 13 اراجخال اذذغت لقان 14 ةيكيينكيجملا تيزلا شر تدحو 15 ةعرسلا يف مكحتلا 16 قنايصل او فيظنتلا قلص



KYM SERIES

KYM 1600



KYM 4800



KYM 1800



KYM 6000



KYM 2000



KYM Pro

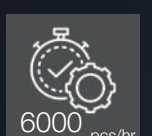

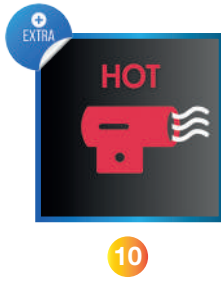
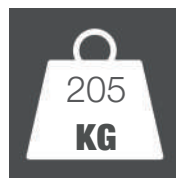
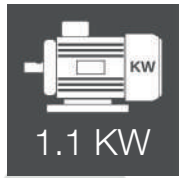

10



9



13

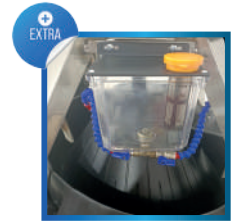

12

KYM 1600 - KYM 1800 - KYM 2000 - KYM 4800

	1000 mm
	1000 mm
	1585 mm

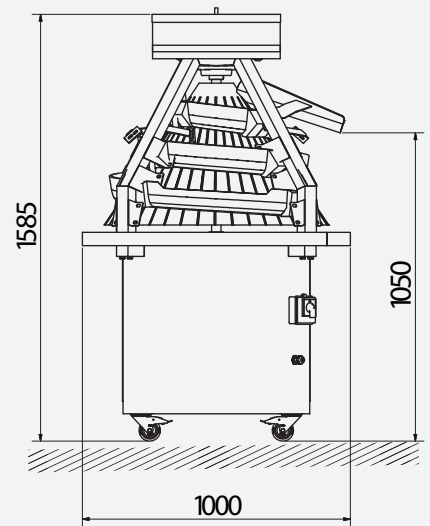
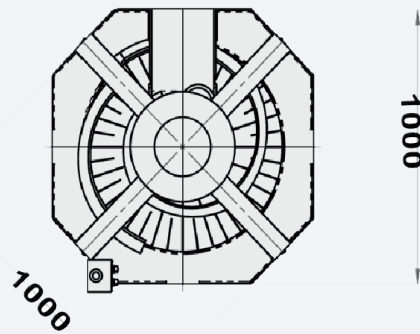

KYM 6000 - KYM PRO*

	1000 mm
	1200 mm
	1700 mm

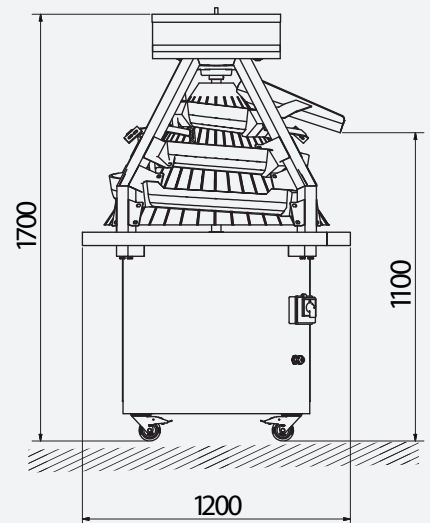
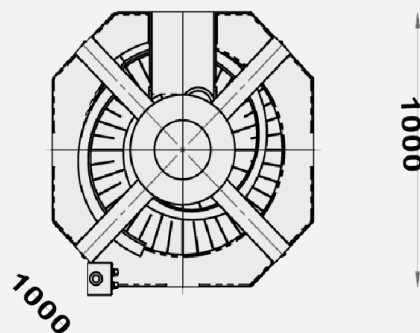



TYM SERIES

*artisan
rounder*





TYM 2000



🇹🇷 **1**Büyük Hamur Ustası **2**Teflon Huni ve Yan Kanartlar **3**Eksantrik Ayarı **4**Kol ve Civata İle, Kolay Tambur Altı Temizliği **5**Paslanmaz Panel, Boyalı Şase ve Döküm Huni **6**Yan Sabitleyiciler **7**Sabit Tekerler **8**Band Yükseklik Ayarı **9**Polyester Hamur Çıkış Bandı **10**Hız Ayarı **11**PVC Band(+) **12**Keçe Kaplı Huni ve Kanal **13**Unlama Ünitesi(+) **14**Yağlama Ünitesi(+) **15**Analog Kontrol Panel **16**Kolay Temizlik ve Bakım

🇬🇧 **1**suitable for artisan big dough **2**teflon coated cone & channels **3**eccentric adjustment handle **4**handles, easy to remove the cone **5**aluminum cast cone, stainless steel panels, painted iron structure **6**anti vibration feets **7**fixed wheels **8**adjustable belt height (3 level) **9**polyester conveyor belt for output **10**speed control **11**pvc belt(+) **12**felt coated cone & channel(+) **13**external flour shifter(+) **14**external oil sprayer(+) **15**analogue control panel **16**easy to clean & maintenance

🇪🇸 **1**apto para masas artesanas, grandes **2**cono y canales recubiertos de teflón **3**manivela para ajuste de excéntrica **4**manijas para remover el cono con facilidad **5**cono de aluminio fundido, paneles de inox, estructura de hierro pintado **6**patas de anti-vibración **7**ruedas fijas **8**cinta ajustable (3 nivel) **9**cinta transportadora de poliéster en salida **10**variador de velocidad **11**cinta de pvc(+) **12**cono y canal recubiertos de fieltro(+) **13**external enharinadora(+) **14**external rociador de aceite(+) **15**analógico control **16**fácil de limpiar y mantener



Boledora Excéntrica - Bouleuse Excentrique - Exzenter Rundwirken Arrotondatrice Eccentrica - Különc Gömbölyítő экцентричный Тестоокруглитель - بيړغ نيچ عاړي ووت قن يكيام



1 adapté pour les pâtes artisanales, grands 2 cônes et canaux recouverts de téflon 3 manivelle pour réglage excentrique 4 poignées pour retirer facilement le cône 5 cône en aluminium moulé, panneaux en acier inoxydable, structure en fer peint 6 pieds anti-vibrations 7 roues fixes 8 ruban réglable (3 niveaux) 9 bande transporteuse en polyester à la sortie 10 réglage de la vitesse 11 réglage de la vitesse, bande en pvc(+) 12 cône et canal recouverts de feutre(+) 13 farineuse externe(+) 14 pulvérisateur d'huile externe(+) 15 contrôle analogique 16 facile à nettoyer et entretenir tapis motorisé d'alimentation en pâte

1 Geeignet Für Den Kunsthandwerker Großer Teig 2 teflonbeschichteter kegel und kanäle 3 exzentrischer einstellgriff 4 griffe, einfache entfernung des kegels 5 aluminiumgusskegel, edelstahlplatten, lackierte eisenstruktur 6 anti-vibrationsfüsse 7 feste räder 8 einstellbare bandhöhe (3 stufen) 9 polyester-förderband für die ausgabe 10 geschwindigkeitsregelung 11 pvc-band(+) 12 filzbeschichteter kegel und kanal(+) 13 externer mehlschieber(+) 14 externes ölsprüngerät(+) 15 analoges bedienfeld 16 einfach zu reinigen und zu warten

1 adatto per impasti artigianali, di grandi dimensioni 2 cono e canali rivestiti in teflon 3 manovella per regolazione eccentrica 4 maniglie per una facile rimozione del cono 5 cono in fusione di alluminio, pannelli in acciaio inox, struttura in ferro verniciato 6 gambe antivibranti 7 ruote fisse 8 nastro regolabile (3 livelli) 9 nastro trasportatore in poliestere a produzione 10 velocità variabile 11 nastro in pvc(+) 12 cono e canale rivestiti in feltro(+) 13 sfarinatore esterno(+) 14 spruzzatore esterno per olio(+) 15 controllo analogico 16 facile da pulire e mantenere

1 adequado para massas artesanais, grandes 2 cone e canais revestidos em teflon 3 manivela para ajuste excêntrico 4 alças para fácil remoção do cone 5 cone em alumínio fundido, painéis em aço inox, estrutura em ferro pintado 6 pernas anti-vibração 7 rodas fixas 8 cinto ajustável (3 níveis) 9 correia transportadora em poliéster em saída 10 velocidade variável 11 cinto de pvc(+) 12 cone e canal coberto com feltro(+) 13 farinha externa(+) 14 pulverizador externo de óleo(+) 15 controle analógico 16 fácil de limpar e manter

1 kézműves nagy tésztákhoz alkalmas 2 teflon bevonatú kúp és csatornák 3 excentrikus beállító fogantyú 4 fogantyúk, könnyen eltávolítható a kúp 5 alumínium öntött kúp, rozsdamentes acél panelek, festett vas szerkezet 6 rezgéscsillapító lábak 7 fix kerek 8 állítható övmagasság (3 szint) 9 poliészter szállítószalag a kimenethez 10 sebességszabályozás 11 pvc szalag(+) 12 nemezbevonatú kúp és csatorna(+) 13 külső lisztváltó(+) 14 külső olajpermetező(+) 15 analóg kezelőpanel 16 könnyen tisztítható és karbantarthatósázkmai tészta centrál

1 Подходит для приготовления большого теста 2 Конус и каналы с тефлоновым покрытием 3 Эксцентриковая регулировочная ручка 4 Ручки, конус легко снимается 5 Литой алюминиевый конус, панели из нержавеющей стали, конструкция из окрашенного железа 6 Антивибрационные ножки 7 Фиксированные колеса 8 Регулируемая высота ремня (3 уровня) 9 Конвейерная лента из полиэстера для вывода 10 Регулировка скорости 11 Ремень из ПВХ (+) 12 Конус и канал с фетровым покрытием(+) 13 Внешний механизм перемещения муки(+) 14 Внешний масляный распылитель(+) 15 Аналоговая панель управления 16 Легко чистить и обслуживать

1 موږ يېمول آل نم بېوېصم طورخم 5 طورخم لښار لاسي، ضرباقم 4 راوطلال بېړغ ليدعت ضربقم 3 نولفتل اب ټيلطم تاونقو طورخم 2 يفرحل اړي بڼكلا نيچ عاړل بسا نم 9 رتس يلو بېلا نم لقان مازح 9 (تايو تسم 3) ليدعتل ل لباق مازح ل عافترا 8 تبتا تالاج 7 زازت هال دناضم مادي 6 ي لطملا ديدحل نم لکيه، ادرلل جواقلما ذالو فلما نم حاولا فسيظن تلا غل س 16 ټيرظان ت مکت حو ل 15 (+) ي جراخ تيز خاخب 14 (+) ي جراخ لقي قيدل لقان 13 (+) دابل اب ټيلطم تاونقو طورخم 12 (+) PVC مازح 11 ټرسلا ي ف مکت حو ل 10 جراخل قن ايصل او

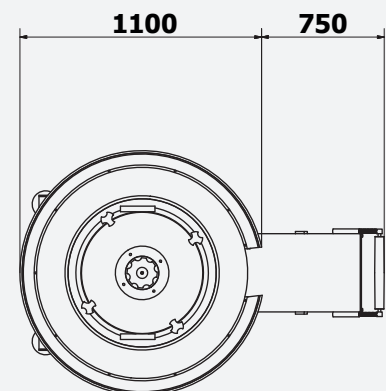
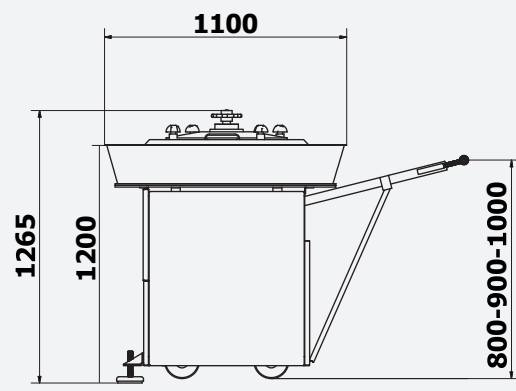
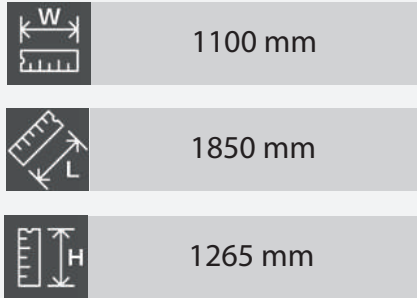
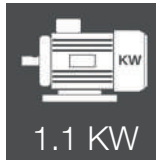



ADM SERIES

proofers





🇹🇷 **1**Unlama **2**Tamamı Demonte Kurulum **3**Hamur Örselemeyen Mekanik Besleme (ön/arka/sol/sağ) **4**LED Makine Altı Aydınlatma **5**Tamamı Paslanmaz Profil ve Gövde **6**Değiştirilebilir Hamur Çıkış Oluğu **7**3 x Makine Gözlem Penceresi **8**3 x Paslanmaz Un Tepsisi **9**Sabit Tekerler,Kolay Hareket **10**Yıkanır, Değişir Kare Tül Tas **11**Önder® İmalat Sessiz, Uzamaz Zincir **12**Askı, Zincir ve Motor Koruma Güvenlik Şaftı **13**İç Hava Temizleme Fanı(+) **14**Dur-Kalk Photosel(+) **15**Anti-Bakteriyel UV Lamba(+) **16**Hız Ayarı(+) **17**PLC Dokunmatik Ekran(+) **18**Analog Kontrol Paneli **19**Kolay Bakım

🇬🇧 **1**flour duster **2**entire modular structure, easy installation **3**"drum cylindrical" type infeed system for gently dough transferring & variable position(front/back/left/right) **4**LED lamp **5**profiles and structure made of stainless steel **6**variable discharge chute(left/right) **7**3 x monitoring windows **8**3 x stainless steel trays to recycle **9**wheels, easy to move **10**polyethylene, washable-removable - square mesh pockets **11**önder® design; noiseless, durable, balanced chain **12**shear pin for chain, rows & motor safety **13**exhaust air fan(+) **14**infeed with photocell(+) **15**antibacterial uv lamp(+) **16**speed control (+) **17**PLC touch screen(+) **18**analog control panel **19**easy maintenance & clean

🇪🇸 **1**enharinadora **2**completa estructura modular, fácil instalación **3**sistema de alimentación en forma "tambor cilíndrico" para transferir suavemente masas y posición variable (delante/detrás/izquierda/derecha) **4**LED lámparas **5**perfiles y estructura de inox **6**variable rampa de depósito (izquierda/derecha) **7**3 x ventana de supervisión **8**3 x bandejas de inox para reciclaje **9**ruedas, fácil de desplazar **10**polietileno, lavable-removable - nichos cuadrados **11**önder® diseño;cadena silenciosa, durable y estable **12**barra para proteger cadena, cargadoras y motor **13**ventilador extractor de air(+) **14**entrada con fotocélula(+) **15**antibacteriano uv lámpara(+) **16**variador de velocidad(+) **17**PLC pantalla táctil(+) **18**análogo panel de control **19**fácil mantenimiento y limpieza



Cámaras De Reposo - Chambre De Repos - Vorgärschränke Cella Di Prefermentazione Câmara De Repouso - Köztes Pihentető Шкаф Предварительной Расстойки آنيج عا حي يرتو حي حصت ءل



1 enrobeuse 2 structure modulaire complète, installation facile 3 système d'alimentation en forme de "tambour cylindrique" pour transférer en douceur les pâtes et position variable (avant/arrière/gauche/droite) 4 lampes led 5 profils et structure en acier inoxydable 6 rampe de dépôt variable (gauche/droite) 7 3 x fenêtres de surveillance 8 3 x plateaux en acier inoxydable pour recyclage 9 roues, facile à déplacer 10 polyéthylène, lavable-amovible-niches carrées 11 conception önder®; chaîne silencieuse, durable et stable 12 barre de protection de la chaîne, des chargeurs et du moteur 13 extracteur d'air(+) 14 entrée avec cellule photoélectrique(+) 15 lampe uv antibactérienne(+) 16 variateur de vitesse(+) 17 écran tactile plc(+) 18 panneau de commande analogique 19 facile d'entretien et de nettoyage

1 mehlstauber 2 gesamte modulstruktur, einfache installation 3 "trommelzylindrisch" typ einzugsystem für schonenden teigtransfer & variable position (vorne / hinten / links / rechts) 4 led-lampe 5 profile und struktur aus edelstahl 6 variable austragsrinne (links / rechts) 7 3 x überwachungsfenster 8 3 x edelstahltablets zum recyceln 9 räder, einfach zu bewegen 10 polyethylen, abwaschbar-entfernbar - quadrierungsgittertaschen 11 önder® design; geräuschlos, langlebig, ausbalancierte kette 12 scherstift für ketten-, reihen- und motorsicherheit 13 abluftventilator(+) 14 einlauf mit fotokelle(+) 15 antibakterielle uv-lampe(+) 16 geschwindigkeitsregelung(+) 17 PLC-touchscreen(+) 18 analoges bedienfeld 19 einfache wartung & reinigung

1 macchina rivestitrice 2 struttura modulare completa, facile da installare 3 sistema di alimentazione a forma di "tamburo cilindrico" per trasferire delicatamente la pasta e posizione variabile (avanti/indietro/sinistra/destra) 4 luci a led 5 profili e struttura in acciaio inossidabile 6 rampa di deposito variabile (sinistra/destra) 7 3 x finestre di controllo 8 3 x vassoi in acciaio inossidabile per il riciclo 9 ruote, facile da spostare 10 polietilene, lavabile-removibile-nicchie quadrate 11 design önder®; catena silenziosa, resistente e stabile 12 barra di protezione per la catena, i caricatori e il motore 13 estrattore d'aria(+) 14 ingresso con cellula fotoelettrica(+) 15 lampada uv antibatterica(+) 16 regolatore di velocità(+) 17 schermo touch PLC(+) 18 pannello di controllo analogico 19 facile da mantenere e pulire

1 enharinador 2 estrutura modular completa, fácil de instalar 3 sistema de alimentação em forma de "tambor cilíndrico" para transferência suave de massas e posição variável (frente/trás/esquerda/direita) 4 lâmpadas de led 5 perfis e estrutura de aço inoxidável 6 rampa de depósito variável (esquerda/direita) 7 3 x janelas de supervisão 8 3 x bandejas de aço inoxidável para reciclagem 9 rodas, fácil de mover 10 polietileno lavável-removível - nichos quadrados 11 design önder®; corrente silenciosa, durável e estável 12 barra de proteção para corrente, carregadores e motor 13 ventilador exaustor de ar(+) 14 entrada com fotocélula(+) 15 lâmpada uv antibacteriana(+) 16 variador de velocidade(+) 17 tela sensível ao toque plc(+) 18 painel de controle analógico 19 fácil manutenção e limpeza

1 lisztoszóró 2 teljes moduláris szerkezet, könnyű telepítés 3 dob cilindres" típusú bejárati rendszer óvatosan tészta átviteléhez és változó pozíció (előre/hátra/balra/jobbra) 4 led lámpa 5 profilok és szerkezet rozsdamentes acélból készültek 6 változtható kiserelő cső (bal/job) 7 3 x ellenőrző ablak 8 3 x rozsdamentes acél tálcák újrafelhasználáshoz 9 kerek, könnyen mozgatható 10 polietilén, mosható-eltávolítható - négyzetes hálós zsebek 11 önder® design; zajtalan, tartós, kiegyensúlyozott lánc 12 szakadó csap a lánc, sorok és motor biztonságához 13 szellőző ventilátor 14 bejárat fotocellával 15 antibakteriális uv lámpa 16 sebességvezérlés 17 plc érintőképernyő 18 analóg vezérlő panel 19 egyszerű karbantartás és tisztításlisztporoló

1 Пылесборник для муки 2 Весь модульная конструкция, легкая установка 3 Система подачи теста типа "барабан" для бережного перекачивания теста и переменного положения (переднее/заднее/левое/правое) 4 Светодиодные лампы 5 Профили и структура из нержавеющей стали 6 Переменный сливной желоб (левый/правый) 7 3x мониторинговые окна 8 3x металлически лотка для утилизации 9 Колеса, легко перемещать 10 Полиэтилен, моющиеся / съёмные - карманы с квадратной сеткой 11 Дизайн Önder®; бесшумный, прочный, сбалансированная цепь 12 Защитный штифт для цепи, рядов и мотора 13 Вентилятор отработанного воздуха (+) 14 Подача с фотоэлементом(+)
15 Ультрафиолетовая лампа с антибактериальным действием(+) 16 Регулировка скорости(+) 17 PLC сенсорный экран(+) 18 Аналоговая панель управления 19 Легкое обслуживание и чистка

1 لكيو بنو اج LED حابصم 2 قيقدل قضي فم 3 بي كرتلا لس لمك يراي عم لكيه 4 نيمي / راسي / يفلخ / يمام) ري غتم عضو فطلب ني جعلا لقول "ين او طس ال" عونلا نم ذيذغت ماظن 5 انصردل موقا قما ذالوفلا نم عونصم 6 انصردل موقا قما ذالوفلا نم عونصم 7 3x نفاونلا حبقارم 8 3x نفاونلا حبقارم 9 ريودتلا تداعلا انصردل موقا قما ذالوفلا نم ين او ص 10 فكلر حل ا لس ،تال جع 11 انصردل موقا قما ذالوفلا نم عونصم 12 قنزاوتمو قنيتمو اصوص الب قلس لس ، Önder 13 كرحلما قما لس و فوفصل او قلس لس لس ص قلس سوبد 14 (+) مداخل او اه ءحورم 15 انصردل موقا قما ذالوفلا نم عونصم 16 اير يري كبلبل ماضلما اي جيفن بل قوف ءحس ال حابصم 17 (+) اي ويوضور قما 18 PLC مداخل لم عت قشاش 19 نظني & نفاونلا قلس م 20 انصردل موقا قما ذالوفلا نم عونصم

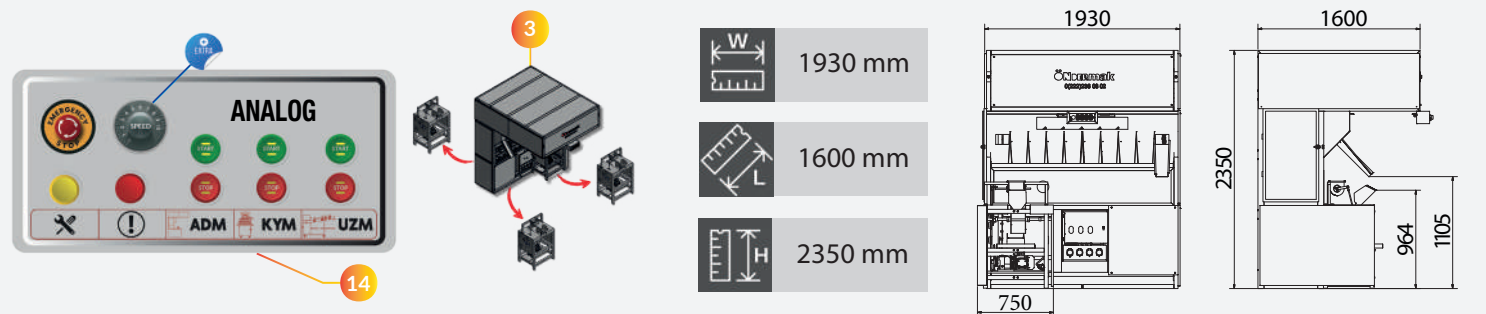
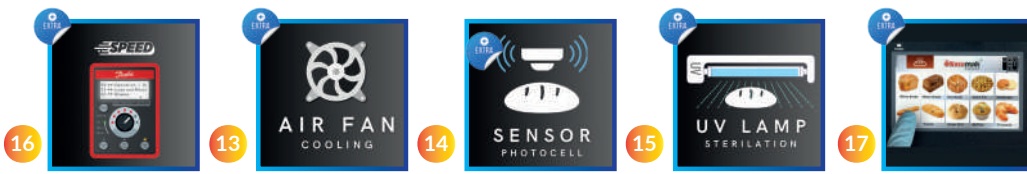



Ç* 1 Unlama 2 Tamamı Demonte Kurulum 3 Hamur Örsellemeyen Mekanik Besleme (ön/arka/sol/sağ) 4 LED Makine Altı Aydınlatma 5 Tamamı Paslanmaz Profil ve Gövde 6 Değiştirilebilir Hamur Çıkış Oluğu 7 3 x Makine Gözlem Penceresi 8 3 x Paslanmaz Un Tepsisi 9 Sabit Tekerler, Kolay Hareket(+) 10 Yıkınır, Değişir Kare Tül Tas 11 Önder® İmalat Sessiz, Uzamaz Zincir 12 Askı, Zincir ve Motor Koruma Güvenlik Şaftı 13 İç Hava Temizleme Fanı(+) 14 Dur-Kalk Photosel(+) 15 Anti-Bakteriyel UV Lamba(+) 16 Hız Ayarı(+) 17 PLC Dokunmatik Ekran(+) 18 Analog Kontrol Paneli 19 Kolay Bakım

UK 1 flour duster 2 entire modular structure, easy installation 3 "drum cylindrical" type infeed system for gently dough transferring & variable position(front/back/left/right) 4 led lamp 5 profiles and structure made of stainless steel 6 variable discharge chute(left/right) 7 3 x monitoring windows 8 3 x stainless steel trays to recycle 9 wheels, easy to move(+) 10 polyethylene, washable-removable - square mesh pockets 11 önder® design; noiseless, durable, balanced chain 12 shear pin for chain, rows & motor safety 13 exhaust air fan (+) 14 infeed with photocell(+) 15 antibacterial UV lamp(+) 16 speed control (+) 17 PLC touch screen(+) 18 analog control panel 19 easy maintenance & clean

ES 1 enharinadora 2 completa estructura modular, fácil instalación 3 sistema de alimentación en forma "tambor cilíndrico" para transferir suavemente masas y posición variable (delante/detrás/izquierda/derecha) 4 LED lámparas 5 perfiles y estructura de inox 6 variable rampa de deposito (izquierda/derecha) 7 3 x ventana de supervisión 8 3 x bandejas de inox para reciclaje 9 ruedas, fácil de desplazar(+) 10 polietileno, lavable-removible - nichos cuadrados 11 önder® diseño; cadena silenciosa, durable y estable 12 barra para proteger cadena, cargadoras y motor 13 ventilador extractor de air(+) 14 entrada con fotocélula(+) 15 antibacteriano uv lámpara(+) 16 variador de velocidad(+) 17 PLC pantalla táctil(+) 18 análogo panel de control 19 fácil mantenimiento y limpieza



Cámaras De Reposo - Chambre De Repos - Vorgärschränke Cella Di Prefermentazione - Câmara De Repouso - Köttes Pihentető Шкаф Предварительной Расстойки - آني جعلا حي يرتو حي حصت ؤلآ



1 enrobeuse **2** structure modulaire complète, installation facile **3** système d'alimentation en forme de "tambour cylindrique" pour transférer en douceur les pâtes et position variable (avant/arrière/gauche/droite) **4** lampes led **5** profils et structure en acier inoxydable **6** rampe de dépôt variable (gauche/droite) **7** 3 x fenêtres de surveillance **8** 3 x plateaux en acier inoxydable pour recyclage **9** roues, facile à déplacer(+) **10** polyéthylène, lavable-amovible-niches carrées **11** conception önder®; chaîne silencieuse, durable et stable **12** barre de protection de la chaîne, des chargeurs et du moteur **13** extracteur d'air(+) **14** entrée avec cellule photoélectrique(+) **15** lampe uv antibactérienne(+) **16** variateur de vitesse(+) **17** écran tactile plc(+) **18** panneau de commande analogique **19** facile d'entretien et de nettoyage

1 mehlmästauber **2** gesamte modulstruktur, einfache installation **3** "trommelzylindrisch" typ einzugsystem für schonenden teigtransfer & variable position (vorne / hinten / links / rechts) **4** led-lampe **5** profile und struktur aus edelstahl **6** variable austragsrinne (links / rechts) **7** 3 x überwachungsfenster **8** 3 x edelstahltablets zum recyceln **9** räder, einfach zu bewegen(+) **10** polyethylen, abwaschbar-entfernbar - quadrierungsgittertaschen **11** önder® design; geräuschlos, langlebig, ausbalancierte kette **12** scherstift für ketten-, reihen-und motorsicherheit **13** abluftventilator(+) **14** einlauf mit fotokelle(+) **15** antibakterielle uv-lampe(+) **16** geschwindigkeitsregelung(+) **17** plc-touchscreen(+) **18** analoges bedienfeld **19** einfache wartung & reinigung

1 macchina rivestitrice **2** struttura modulare completa, facile da installare **3** sistema di alimentazione a forma di "tamburo cilindrico" per trasferire delicatamente la pasta e posizione variabile (avanti/indietro/sinistra/destra) **4** luci a led **5** profili e struttura in acciaio inossidabile **6** rampa di deposito variabile (sinistra/destra) **7** 3 x finestre di controllo **8** 3 x vassoi in acciaio inossidabile per il riciclo **9** ruote, facile da spostare(+) **10** polietilene, lavabile-removibile-nicchie quadrate **11** design önder®; catena silenziosa, resistente e stabile **12** sbarra di protezione per la catena, i caricatori e il motore **13** estrattore d'aria(+) **14** ingresso con cellula fotoelettrica(+) **15** lampada uv antibatterica(+) **16** regolatore di velocità(+) **17** schermo touch plc(+) **18** pannello di controllo analogico **19** facile da mantenere e pulire

1 enharinador **2** estrutura modular completa, fácil de instalar **3** sistema de alimentación en forma de "tambor cilíndrico" para transferencia suave de masas e posición variável (frente/trás/esquerda/direita) **4** lâmpadas de led **5** perfis e estrutura de aço inoxidável **6** rampa de depósito variável (esquerda/direita) **7** 3 x janelas de supervisão **8** 3 x bandejas de aço inoxidável para reciclagem **9** rodas, fácil de mover(+) **10** polietileno lavável-removível - nichos quadrados **11** design önder®; corrente silenciosa, durável e estável **12** barra de proteção para corrente, carregadores e motor **13** ventilador exaustor de ar(+) **14** entrada com fotocélula(+) **15** lâmpada uv antibacteriana(+) **16** variador de velocidade(+) **17** tela sensível ao toque plc(+) **18** painel de controle analógico **19** fácil manutenção e limpeza

1 lisztzóró **2** teljes moduláris szerkezet, könnyű telepítés **3** "dob cilinderes" típusú bejárati rendszer óvatosan tészta átviteléhez és változó pozíció (előre/hátra/balra/jobbra) **4** led lámpa **5** profilok és szerkezet rozsdamentes acélból készültek **6** változtatható kiszorító cső (bal/jobb) **7** 3 x ellenőrző ablak **8** 3 x rozsdamentes acél tálcák újrafelhasználáshoz **9** kerekek, könnyen mozgatható(+) **10** polietilén, mosható-eltávolítható - négyzetes hálós zsebek **11** önder® design; zajtalan, tartós, kiegyensúlyozott lánc **12** szakadó csap a lánc, sorok és motor biztonságához **13** szellőző ventilátor **14** bejárat fotocellával **15** antibakteriális uv lámpa **16** sebességvezérlés **17** plc érintőképernyő **18** analóg vezérlő panel **19** egyszerű karbantartás és tisztításlisztporoló

1 Пылесборник для муки **2** Весь модульная конструкция, легкая установка **3** Система подачи теста типа "барабан" для бережного перекачивания теста и переменного положения (переднее/заднее/левое/правое) **4** Светодиодные лампы **5** Профили и структура из нержавеющей стали **6** Переменный сливной желоб (левый/правый) **7** 3x мониторинговые окна **8** 3x металлические лотка для утилизации **9** Колеса, легко перемещать(+) **10** Полиэтилен, моющиеся / съемные - карманы с квадратной сеткой **11** Дизайн Önder®, бесшумный, прочный, сбалансированная цепь **12** Защитный штифт для цепи, рядов и мотора **13** Вентилятор отработанного воздуха (+) **14** Подача с фотоэлементом(+) **15** Ультрафиолетовая лампа с антибактериальным действием(+) **16** Регулировка скорости(+) **17** PLC сенсорный экран(+) **18** Аналоговая панель управления **19** Легкое обслуживание и чистка

لكيهو بنواج LED **5** حابصم (نيمي / راسي / يفلخ / يمام) ري غتم عضوو فطلب ني جعلا لقنل "ين اوطس ال" عونلا نم يذغت ماظن **3** بي كرتلا لس، لمك يراي عم لكي **2** قي قدل تضفم **1** نيل يثي يلوب **10** (تفرحلا لئس، تالاج **9** ريوتلا تداخل ائصلل مواقلا ذالوفلا نم ين اوص **8** 3x ذفاونلا قبقارم **7** 3x (نيمي / راسي) ري غتم غيرفت يرجم **6** ائصلل مواقلا ذالوفلا نم عونصم قيل خلاب يذغت **14** (+) مداغلا عاوه **13** كرحملا قمالسو فوفصل او لئسل لئل صرقلا سوبد **12** تزاوتومو قنيتمو اءاضوض الب لئسل، Önder **11** عبرم يكي بش بوي ج - طازال او لس غلل لئباق تي رطانم مكحت حول **19** تظني & تنايصل لئل ووس **18** PLC (+) س لئلاب لمخت قشاش **17** (+) عرسلا ي ف مكحتل **16** (+) اي ريتا فبلل داضملا اي جيفن بل ا قوف عشا ال ا حابصم **15** (+) اي ووضور طكلا

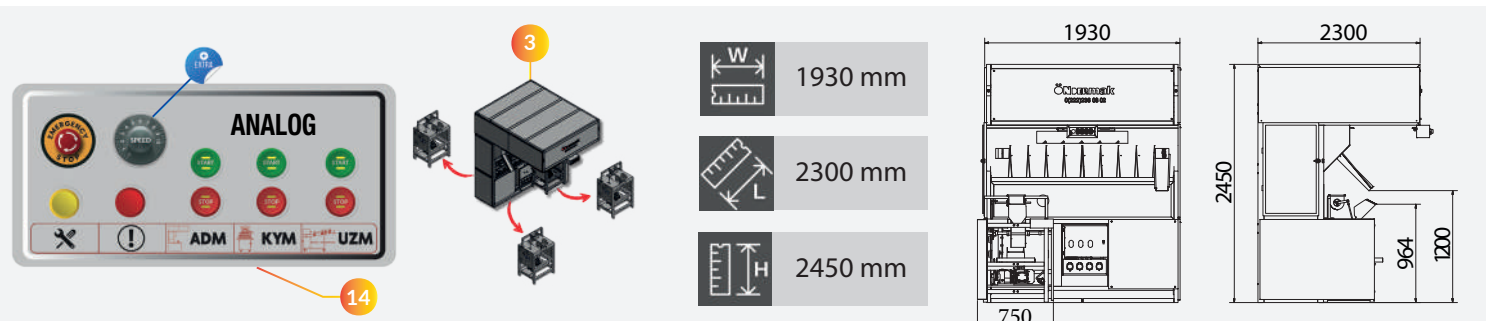
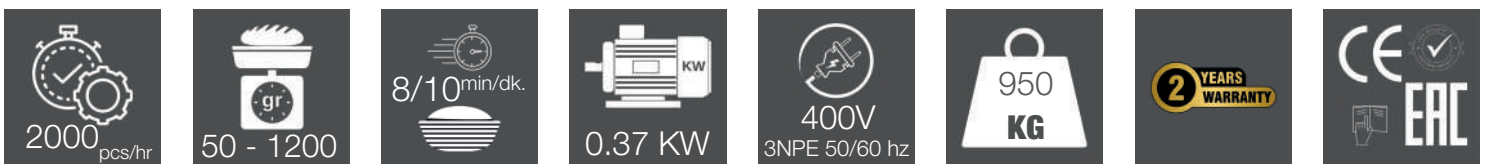

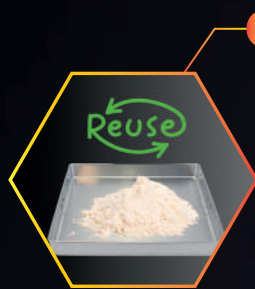
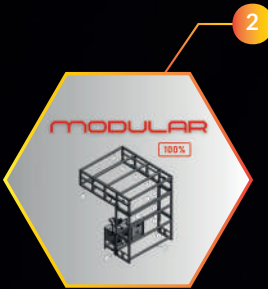
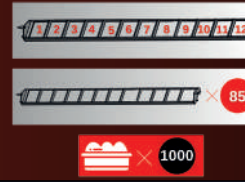

1 Unlama 2 Tamamı Demonte Kurulum 3 Band Tertibatlı Pnmatik Besleme(ön/arka/sol/sağ) 4 LED Makine Altı Aydınlatma 5 Tamamı Paslanmaz Profil ve Gövde 6 Konveyör Tip Klepeli Boşaltma Tertibatı 7 3 x Makine Gözlem Penceresi 8 3 x Paslanmaz Un Tepsisi 9 Hava Tertibatı 10 Yıkınır, Değişir Kare Tül Tas 11 Önder® İmalat Sessiz, Uzamaz Zincir 12 Askı, Zincir ve Motor Koruma Güvenlik Şaftı 13 İç Hava Temizleme Fanı 14 Dur-Kalk Photosel 15 Anti-Bakteriyel UV Lamba 16 Hız Ayarı 17 PLC Dokunmatik Ekran(+) 18 PLC Analog Kontrol Paneli 19 Kolay Bakım

1 flour duster 2 entire modular structure, easy installation 3 pneumatic – conveyor belt infeed system & variable position(front/back/left/right) 4 led lamp 5 profiles and structure made of stainless steel 6 independent discharge conveyor with sorting flap 7 3 x monitoring windows 8 3 x stainless steel trays to recycle 9 air gun for cleaning 10 polyethylene, washable-removable - square mesh pockets 11 önder® design; noiseless, durable, balanced chain 12 shear pin for chain, rows & motor safety 13 exhaust air fan(+) 14 infeed with photocell 15 antibacterial uv lamp 16 speed control 17 plc touch screen(+) 18 plc analog control panel 19 easy maintenance & clean

1 enharinadora 2 completa estructura modular, fácil instalación 3 sistema de alimentación neumática con cinta transportadora al acceso y posición variable (delante/detrás/izquierda/derecha) 4 led lámparas 5 perfiles y estructura de inox 6 independiente cinta transportadora para descargar, equipada con aleta para clasificar masas 7 3 x ventana de supervisión 8 3 x bandejas de inox para reciclaje 9 pistola de aire para limpieza 10 polietileno, lavable-removable – nichos cuadrados 11 önder® diseño; cadena silenciosa, durable y estable 12 barra para proteger cadena, cargadoras y motor 13 ventilador extractor de air 14 entrada con fotocélula 15 antibacteriano uv lámpara 16 variador de velocidad 17 plc pantalla táctil(+) 18 plc análogo panel de control 19 fácil mantenimiento y limpieza



Cámaras De Reposo - Chambre De Repos - Vorgärschränke
 Cella Di Prefermentazione - Câmara De Repouso - Kőztes Pihentető
 Шкаф Предварительной Расстойки - آي جي رتو حي حصت ؤلآ



1 enrobeuse 2 structure modulaire complète, installation facile 3 système d'alimentation pneumatique avec accessoire de bande transporteuse et position variable (avant/arrière/gauche/droite) 4 lampes led 5 profils et structure en acier inoxydable 6 convoyeur à bande indépendant pour déchargement, équipé d'un déflecteur pour trier les masses 7 3 x fenêtres de surveillance 8 3 x plateaux en acier inoxydable pour recyclage 9 pistolet à air pour le nettoyage 10 polyéthylène, lavable-amovible-niches carrées 11 conception önder®; chaîne silencieuse, durable et stable 12 barre de protection de la chaîne, des chargeurs et du moteur 13 extracteur d'air 14 entrée avec cellule photoélectrique 15 lampe uv antibactérienne 16 variateur de vitesse 17 écran tactile plc(+) 18 panneau de commande analogique plc 19 facile d'entretien et de nettoyage

1 mehlstauber 2 gesamte modulstruktur, einfache installation 3 pneumatisches fōrdersystem mit fōrderband am zugang & variable position (vorne / hinten / links / rechts) 4 led-lampe 5 profile und struktur aus edelstahl 6 unabhāngiges austragsfōrderband mit sortierereinrichtung 7 3 x ūberwachungsfenster 8 3 x edelstahltablets zum recyceln 9 luftgewehr zur reinigung 10 polyethylen, abwaschbar-entfernbar-quadrierungsgittertaschen 11 ōnder® design; gerāuschlos, langlebig, ausbalancierte kette 12 scherstift fūr ketten-, reihen- und motorsicherheit 13 abluftventilator 14 einlauf mit fotokelle 15 antibakterielle uv-lampe 16 geschwindigkeitsregelung 17 plc-touchscreen(+) 18 plc analoges bedienfeld 19 einfache wartung & reinigung

1 macchina rivestitrice 2 struttura modulare completa, facile da installare 3 sistema di alimentazione pneumatica con nastro trasportatore all'accesso e posizione variabile 4 luci a led 5 profili e struttura in acciaio inossidabile 6 nastro trasportatore indipendente per lo scarico, equipaggiato con flap per classificare le masse 7 3 x finestre di controllo 8 3 x vassoi in acciaio inossidabile per il riciclo 9 pistola ad aria per la pulizia 10 polietilene, lavabile-removibile-nicchie quadrate 11 design önder®; catena silenziosa, resistente e stabile 12 barra di protezione per la catena, i caricatori e il motore 13 estrattore d'aria 14 ingresso con cellula fotoelettrica 15 lampada uv antibatterica 16 regolatore di velocità 17 schermo touch plc(+) 18 plc pannello di controllo analogico 19 facile da mantenere e pulire

1 enharinador 2 estrutura modular completa, fācil de instalar 3 sistema de alimentaēāo pneumātica com esteira transportadora para acesso e posiēāo variāvel (frente/trās/esquerda/direita) 4 lâmpadas de led 5 perfis e estrutura de aēo inoxidāvel 6 transportador de correia independente para descarga, equipado com aletas para classificar materiais 7 3 x janelas de supervisāo 8 3 x bandejas de aēo inoxidāvel para reciclagem 9 pistola de ar comprimido para limpeza 10 polietileno lavāvel-removível - nichos quadrados 11 design önder®; corrente silenciosa, durāvel e estāvel 12 barra de proteēāo para corrente, carregadores e motor 13 ventilador exaustor de aire 14 entrada com fotocélula 15 lâmpada uv antibacteriana 16 variador de velocidade 17 tela sensível ao toque plc(+) 18 painel de controle analógico plc 19 fācil manutenēāo e limpeza

1 lisztšzór 2 teljes modulāris szerkezet, könnyū telepítés 3 pneumatikus - tāpláló rendszer szállítóval a bejāratnál és vāltozó pozíció (előre/hātra/balra/jobbra) 4 led lāmpa 5 profilk és szerkezet rozsdamentes acélból készūltek 6 fūggetlen kiserelős szállító szalag rendezőberendezéssel 7 3 x ellenőrző ablak 8 3 x rozsdamentes acél tálcsák ūjrafelhasználáshoz 9 lēggömbös tisztításhoz 10 polietilén, mosható-eltávolítható - négyzetes hálós zsebek 11 önder® design; zajtalan, tartós, kiegyensúlyozott lānc 12 szakadó csap a lānc, sorok és motor biztonságához 13 szellőző ventilátor 14 bejārat fotocellával 15 antibakteriális uv lāmpa 16 sebességvezérlés 17 plc érintőképernyő(+) 18 plc analóg vezérlő panel 19 egyszerű karbantartás és tisztítāsisztropoló

1 Пылесборник для муки 2 Весь модульная конструкция, легкая установка 3 Пневматическая система подачи с конвейером на входе и переменного положения (переднее/заднее/левое/правое) 4 Светодиодные лампы 5 Профили и структура из нержавеющей стали 6 Конвейер с независимым выгрузом и сортировочным устройством. 7 3x мониторинговые окна 8 3x металлически лотка для утилизации 9 Воздушный пистолет для уборки 10 Полиэтилен, моющиеся / съёмные - карманы с квадратной сеткой 11 Дизайн Önder®; бесшумный, прочный, сбалансированная цепь 12 Защитный штифт для цепи, рядов и мотора 13 Вентилятор отработанного воздуха 14 Подача с фотоэлементом 15 Ультрафиолетовая лампа с антибактериальным действием 16 Регулировка скорости 17 PLC сенсорный экран(+) 18 PLC Аналоговая панель управления 19 Легкое обслуживание и чистка

1 موقعا ذالوفلا نم عون صم لك يهو بن اوج 2 LED احابصم 3 (نمي / راسي / يفلخ / يمام) لوخذلا يف لقان ب يكي تا هو يذب في ذغت ماضن 4 بي كرتلا لس، لم اك يراي عم لك يه 5 قي قدلا قاضف نم 6 انصلل لس غل فل باق، نيل يثي يلوب 7 فيظن تلل في او ه في قدن ب 8 ريونتل اذغال انصلل موقعا ذالوفلا نم ين اوص 9 3x ذفاونلا تبقارم 7 3x زرفلا زاغ عم لقتسمل ا ج ارغال لقان ريس 6 انصلل احابصم 15 في يوضور مللا في لخل اب في ذغت 14 ماذغال او ه جورم 13 كرحملا فم لسو فوفصل لاو لسل لسل لل صرقل ا سوبد 12 قنزاوتمو قنيتمو ءاضوض الب فل لس، Önder® 11 عجرم في كبش بويج - فل ازال او في رظانت مكحت ؤول 19 نظني & قن ا يصل لا لوس PLC(+) 10 PLC 16 يري يتكبلل داضملا في ج سفن بئلا قوف ؤعشالا

11

16

5

14

15

17

3600-6000 pcs/hr

50 - 1200

10/25 min/dk.

1.5 KW

400V
3NPE 50/60 hz

2000
KG

2 YEARS
WARRANTY

CE
EAC

PLC Tech 18

Tam Hat Kontrolü
Pro Supervision
Pro Control

ANALOG

3

W	2250 mm
L	2800 (ADM3600) 3000 (ADM4800) 3200 (ADM6000)
H	2500 (ADM3600) 3000 (ADM4800) 3500 (ADM6000)





KST SERIES

dividers





KST 2000



1 Vakumlu Hamur Kesme 2 Harici Yağ Koyma Yeri 3 Yağ Seviyesi Gözlem Penceresi 4 Manuel Gramaj Ayarı 5 Manuel Motor Kasnak Ayarı 6 Bant Temizleme Fırça Tertibatlı Polyester Band 7 Unlama Ünitesi 8 Un Kabı 9 Eksik Yağ İkazı 10 Paslanmaz Panel ve Platin Gövde 11 Döner Tekerler, Kolay Hareket 12 Çift Yağ Filtresi 13 PVC Band(+) 14 Teflon Huni(+) 15 Hız Ayarı 16 Analog Kontrol Panel 17 Kolay Temizlik ve Bakım

1 suction dividing system 2 external oil filling cap 3 outer oil level meter 4 manual gram adjustment 5 manual motor tension adjustment 6 polyester conveyor with belt cleaner brush 7 flour duster 8 recycle bin 9 low oil level alarm 10 stainless steel panels, hopper & solid platinum structure 11 heavy duty wheels, easy to move 12 dual filtering setup, clean oil 13 pvc belt(+) 14 teflon coated hopper(+) 15 speed control 16 analog control panel 17 easy to clean & maintenance

1 sistema de succión para corte 2 tapa exterior para rellenar aceite 3 indicador externo para el nivel de aceite 4 ajuste manual para gramaje 5 ajuste manual tensión en motor 6 cinta transportadora de poliéster con cepillo a limpiar cinta 7 enharinadora 8 cubo de reciclaje 9 alarma para bajo nivel de aceite 10 paneles y tolva de inox, estructura interior de platino 11 ruedas para mover 12 configurada doble filtración a limpiar aceite 13 cinta de pvc(+) 14 teflonada tolva(+) 15 control de velocidad 16 panel de control analógico 17 facil manejo y limpio



Diviseur Volumétrique - Volumetrischer Teigteiler - Divisore volumetrico

Dugattyús Osztó Gép - Divisor Volumétrico - Объемный делитель

ةيمج حل اني جعلا ةعاطق



1 système d'aspiration pour la découpe 2 couvercle extérieur pour remplir l'huile 3 indicateur externe pour le niveau d'huile 4 réglage manuel du grammage 5 réglage manuel de la tension du moteur 6 bande transporteuse en polyester avec brosse de nettoyage de bande 7 enfarineuse 8 bac de recyclage 9 alarme pour niveaux d'huile bas 10 panneaux et trémie en acier inoxydable, structure intérieure en platine 11 roues pour déplacement 12 double filtration configurée pour nettoyer l'huile 13 bande en pvc(+) 14 trémie revêtue de teflon(+) 15 contrôle de vitesse 16 panneau de contrôle analogique 17 facile à manipuler et à nettoyer

1 Absaugungssystem 2 Externer Ölnachfüllverschluss 3 äusserer ölstandsmesser 4 manuelle grammeinstellung 5 manuelle einstellung der motorspannung 6 polyester-förderband mit bandreinigungsbürste 7 mehlstaub 8 recyclingtonne 9 alarm bei niedrigem ölstand 10 edelstahlpaneele, trichter feste platinumstruktur 11 robuste räder, leicht zu bewegen 12 doppelte filtereinrichtung, sauberes öl 13 pvc-band(+) 14 teflonbeschichteter trichter(+) 15 geschwindigkeitsregelung 16 analoges bedienfeld 17 einfach zu reinigen und zu warten

1 sistema di aspirazione per taglio 2 copertura esterna per riempimento olio 3 indicatore esterno per il livello di olio 4 regolazione manuale della grammatura 5 regolazione manuale della tensione del motore 6 nastro trasportatore in poliestere con spazzola per pulire il nastro 7 infarinatrice 8 contenitore per il riciclaggio 9 allarme per basso livello di olio 10 pannelli e tramoggia in acciaio inossidabile, struttura interna in platino 11 ruote per spostamento 12 doppia filtrazione configurata per pulire l'olio 13 nastro in pvc(+) 14 tramoggia rivestita in teflon(+) 15 controllo della velocità 16 pannello di controllo analogico 17 facile da utilizzare e pulito

1 sistema de sucção para corte 2 tampa exterior para reabastecimento de óleo 3 indicador externo para o nível de óleo 4 ajuste manual para gramatura 5 ajuste manual de tensão no motor 6 esteira transportadora de poliéster com escova de limpeza 7 polvilhadora 8 balde de reciclagem 9 alarme para baixo nível de óleo 10 painéis e funil de inox, estrutura interna de platina 11 rodas para movimentação 12 configurada com dupla filtragem para limpeza de óleo 13 esteira de pvc(+) 14 funil revestido com teflon(+) 15 controle de velocidade 16 painel de controle analógico 17 fácil manuseio e limpeza

1 szivóelosztó rendszer 2 külső olajbetöltő sapka 3 külső olajsztímer 4 manuális gram-beállítás 5 kézi motorfeszültség-beállítás 6 poliészter szállítószalag tisztító kefével 7 lisztporoló 8 lomtár 9 alacsony olajsztímer 10 rozsdamentes acél panelek, garat és tömör platina szerkezet 11 nagy teherbírású kerekek, könnyen mozgatható olajsztíró 12 kettős hengeres 12 szűrős bevonatos garat (+) 15 sebességszabályozás 16 analóg vezérlőpult 17 könnyen tisztítható és karbantartható

1 Система разделения всасывания 2 Внешняя крышка маслосливной горловины 3 Внешний измеритель уровня масла 4 Ручная регулировка граммов 5 Ручная регулировка натяжения двигателя 6 Конвейер из полиэстера с щеткой для очистки ленты 7 Мучной тряпка 8 Корзина для переработки 9 Сигнализация низкого уровня масла 10 Панели из нержавеющей стали, бункер и прочная платиновая конструкция 11 Сверхмощные колеса, легко перемещаться 12 Двойная система фильтрации, чистое масло 13 Ремень из ПВХ(+) 14 Бункер с тефлоновым покрытием(+) 15 Регулятор скорости 16 Аналоговая панель управления 17 Легко чистить и обслуживать

1 مازح ل فيظنت ةأشرف عم رتس يلوب لقان 2 أيودي كرحمل دش طببخ 3 أيودي مارجل ا طببخ 4 جراجلا تيذلا يوتسم سايقم 5 جراجلا تيذلا ةئبعت ةاطخ 6 طفشلا ميسقت ماظن 7 قيشرت دادع 8 ظفرجل ةلس 9 لمحتلا كئيدش تالاج 10 بلصل انيتالبل نم لكيمو سوداق 11 اذصلل مواقلما ذالوفلا نم حاول 12 ضفخنلما تيذلا يوتسم رانزا 13 تالمجل ةلس 14 قيقلا ضفنم 15 قزايصل او فيظنتلا ةلس 16 ةيرظانن مكحت ةحول 17 ةعرسل ا يف مكحتلا 18 (+) نولفتل ا ب يلطم سوداق 19 PVC(+) مازح 20 فيظن تيذ 21 جوزم



W	650 mm - 850 mm (2piston)
L	1450 mm
H	1600 mm - 1750 mm (2piston)

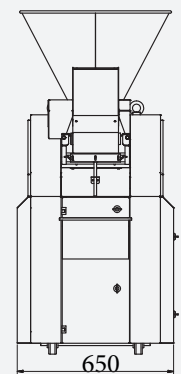
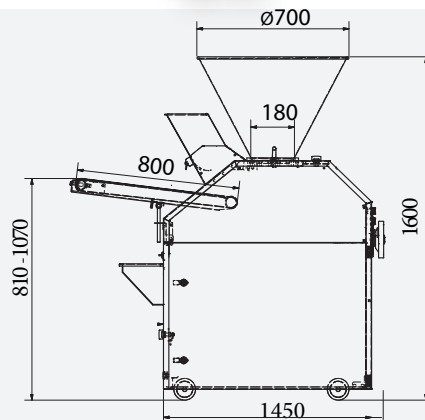

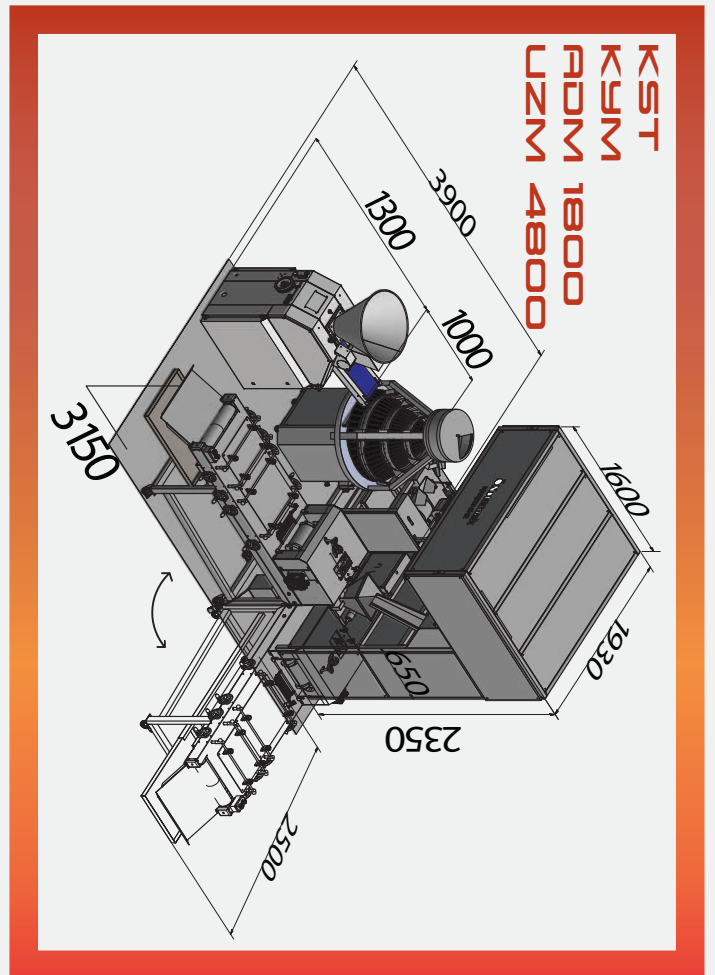
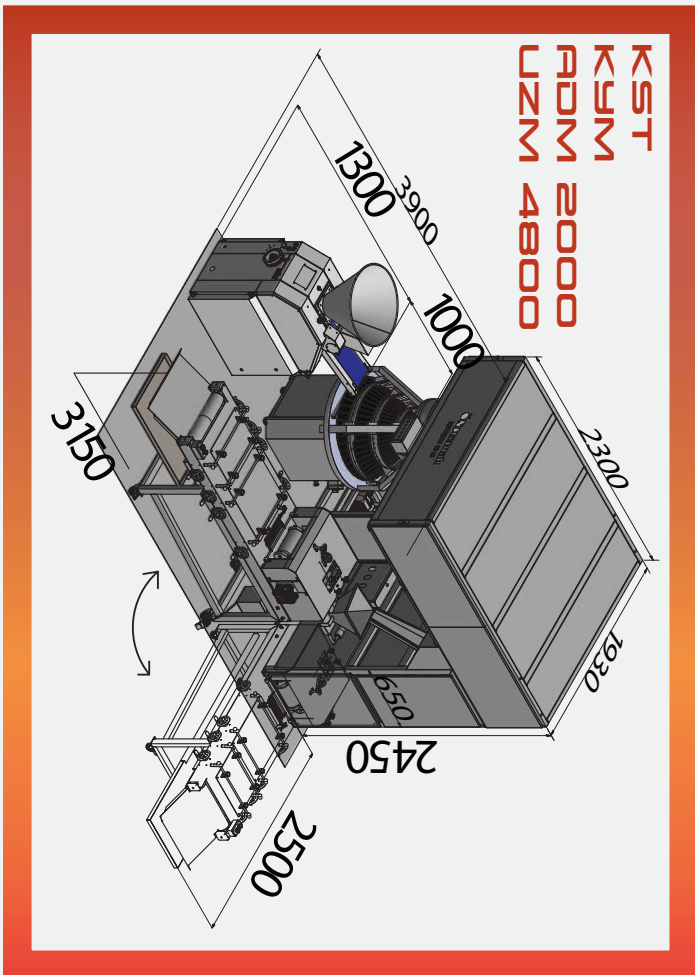
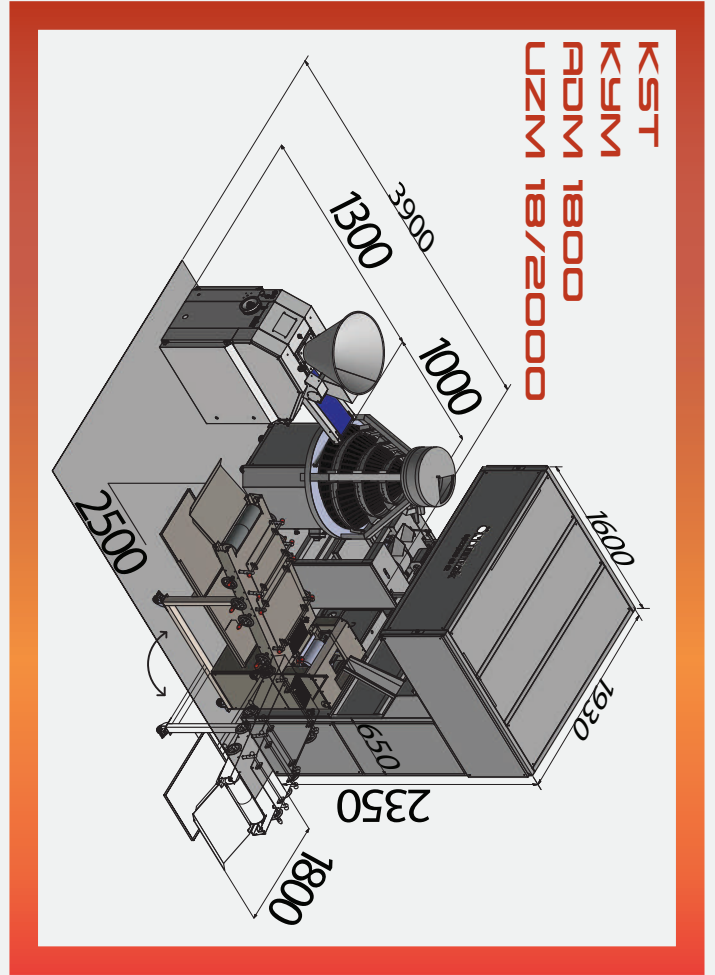
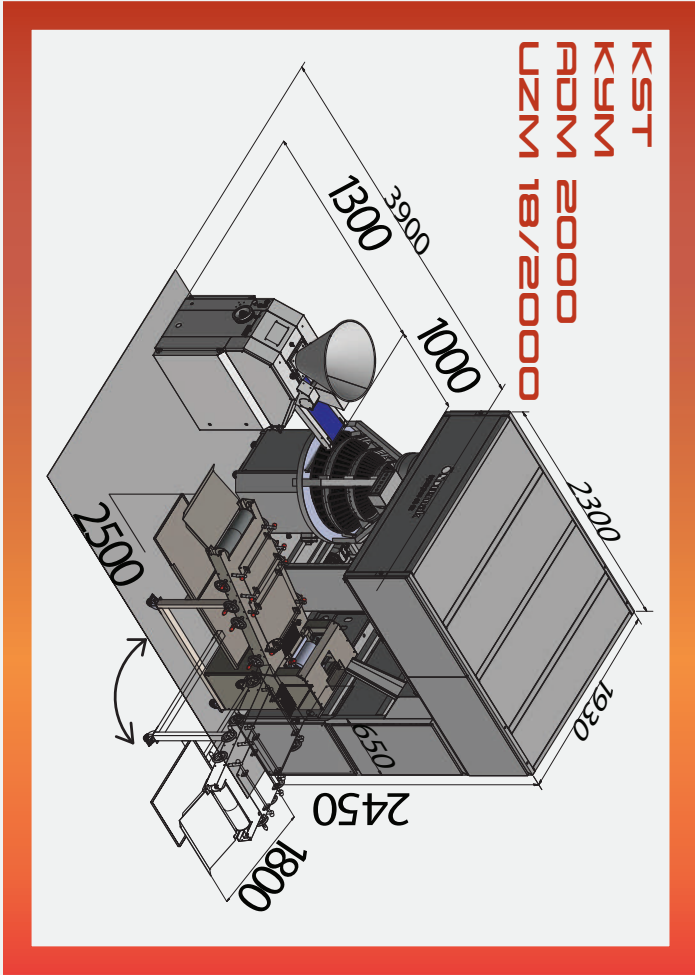



DPT SERIES



paning





Otomatik Dizme - Dough Make Up & Panning System

BMP 2000

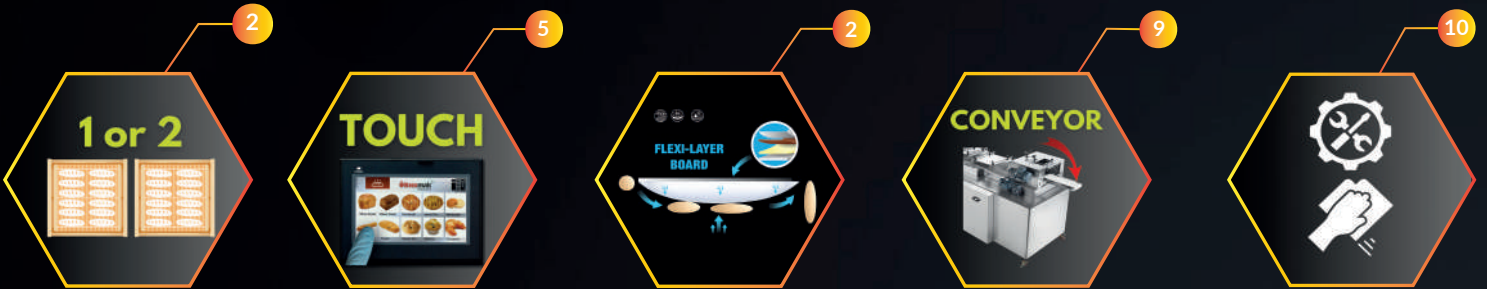

🇹🇷 **1**UZM 4800 Pro Üst Seviye Hamur İşleme(tüm özellikleriyle) **2** x Otomatik "Önder®" Yastık, Flexi-Layer® Tasarım **3**Tek Makineden Çiftli ya da Tekli Tahsürme **4**Farklı Ekmeklerde Başarılı Performans **5** Dokumatik Kontrol Paneli PLC **6**Konveyör Band Giriş **7**Tamamı Paslanlaz Şase **8**Frenli Döner Tekerler **9** Müşteriye Özel Etkili Çözüm **10**Kompakt Tasarım, Modüler Yapı ile Minimum Yer; Kolay Kullanımı Bakım ve Temizlik

🇺🇰 **1**equipped with long moulder UZM4800 for perfect dough forming **2** x motorized "Flexi-Layer®" design pressure boards **3**single or dual dough panning at a time **4**suitable for moulded breads, baguettes and other long rolls **5**touch screen control panel , PLC **6**conveyor belt infeed **7**stainless still finish **8**swivel wheels with brake **9**Custom made solution, one man operation with high efficiency**10** compact design & modular structure for minimum place, easy to use, install and clean

🇪🇸 **1**equipada con la formadora "UZM 4800" para moldear barras perfectamente **2** x motorizados "Flexi-Layer®" tableros de presión **3**Capacidad de colocar panes ya formados en una o dos bandejas por vía de la misma entabladora **4**apropiada para cualquier tipo de barras, panes largos **5** pantalla táctil con PLC **6**cinta transportadora al acceso **7**estructura de completo de INOX **8**ruedas giratorias frenadas **9**soluciones personalizadas, un funcionamiento el mas eficiente y continuo **10**diseño compacto que requiere menos espacio, una estructura modular, fácil manejo y limpiar



Formadora Entabladora - Façonneuse Positionneuse - Teigform und Absetzmaschine - Formatrice, Caricatori Di Vassoio - Formadora, Cargador Bandeja - Sodrok Es Tálabetöltő - линия формовки и укладки - مكنة الخبز الطوي



1 équipé du formeur « UZM 4800 » pour former parfaitement les pâtes 2 2 x planches de pression « Flexi-Layer® » motorisées 3 machine pouvant placer les pâtes travaillées dans un ou deux plateaux 4 adaptée à tout type de barres, pains longs 5 écran tactile avec PLC 6 convoyeur à bande à l'accès 7 structure entièrement en acier inoxydable 8 roues pivotantes freinées 9 solutions personnalisées, fonctionnement le plus efficace et continu 10 conception compacte qui nécessite moins d'espace, une structure modulaire, une manipulation et un nettoyage faciles

1 ausgestattet mit „UZM4800“ für perfekte teigformung 2 2 x motorisierte druckplatten im Flexi-Layer®-design 3 einzel- oder doppelschalenzuführung in derselben maschine 4 geeignet für alle langbrote und baguettes 5 touchscreen-bedienfeld, PLC 6 förderband am eingang 7 struktur besteht aus edelstahl-des-tilliergerät 8 schwenkräder mit bremsen 9 maßgeschneiderte lösung, hohe effizienz der automatisierung 10 kompaktes design und modularer aufbau für minimalen platzbedarf, einfach zu bedienen und zu reinigen

1 dotata della formatrice "UZM 4800" per formare impasti perfettamente 2 2 x pressori motorizzati "Flexi-Layer®" 3 la macchina può posizionare gli impasti lavorati in una o due teglie 4 adatta a qualsiasi tipo di barretta, pane lungo 5 touch screen con PLC 6 nastro trasportatore in accesso 7 struttura interamente in acciaio inox 8 ruote piroettanti con freno 9 soluzioni personalizzate, il funzionamento più efficiente e continuo 10 design compatto che richiede meno spazio, struttura modulare, facile movimentazione e pulizia

1 equipada com o formador "UZM 4800" para formar massas com perfeição 2 2 x tábuas de pressão motorizadas "Flexi-Layer®" 3 máquina pode colocar massas processadas em uma ou duas bandejas 4 adequada para qualquer tipo de barras, pães longos 5 tela sensível ao toque com PLC 6 correia transportadora no acesso 7 estrutura totalmente em aço inoxidável 8 rodas giratórias com freio 9 soluções personalizadas, operação mais eficiente e contínua 10 design compacto que requer menos espaço, estrutura modular, fácil manuseio e limpeza

1 UZM4800-zal felszerelve a tökéletes tésztaformázás érdekében 2 2x motorizált Flexi-Layer® kivitelű nyomólap 3 egy- vagy kéttálcás adagolás ugyanabban a gépben 4 bármilyen hosszú kenyérhez, bagetthez alkalmas 5 érintőképernyős vezérlőpanel, PLC 6 bejáratnál vagy szállítószalagból készült rozsdamentes álló 8 forgó kerekek fékkel 9 Egyedi megoldás, nagy hatékonyságú automatizálás 10 kompakt kialakítás és moduláris felépítés a minimális elhelyezés érdekében, könnyen használható és tisztítható

1 оснащен «UZM4800» для идеального формирования теста 2 2 моторизованные прижимные доски конструкции Flexi-Layer® 3 подача одного или двух лотков в одной машине 4 подходит для любых длинных хлебов, багетов 5 сенсорная панель управления, ПЛК 6 конвейерная лента на входе 7 конструкция изготовлена из нержавеющей стали 8 поворотные колеса с тормозом 9 индивидуальное решение, высокая эффективность автоматизации 10 компактный дизайн и модульная конструкция занимают минимум места, просты в использовании и чистке

1 أو يوط زب خي آل بسانم 4 نكي كالمال سفن ي فة ووزم أو ة درفم ةي نكي ذغت 3 كرحم ةدوزم Flexi-Layer® مي صتب طغض واحول 2 2 ي لاثم لكش ب نكي جع لال كيشتل "UZM4800" ب ةزهجم 5 تي جاب زب خي لال لاي غشت لال ي في لال ةءافكو بل طلال بسح و نوصم لحي 9 لم ارف عم اءصل لل ةلباق ريغ ةراود تال جع نم عونصم لك يه لال 7 لخدمل اذنع لقان مزاح PLC 6 سم لال اب لمحت ةحول 5 تي جاب زب خي لال لاي غشت لال او م اءخت سالا لهس ناكم ين ذال يراي عم لك يه وجم ممي صت 10 في ظنت لال

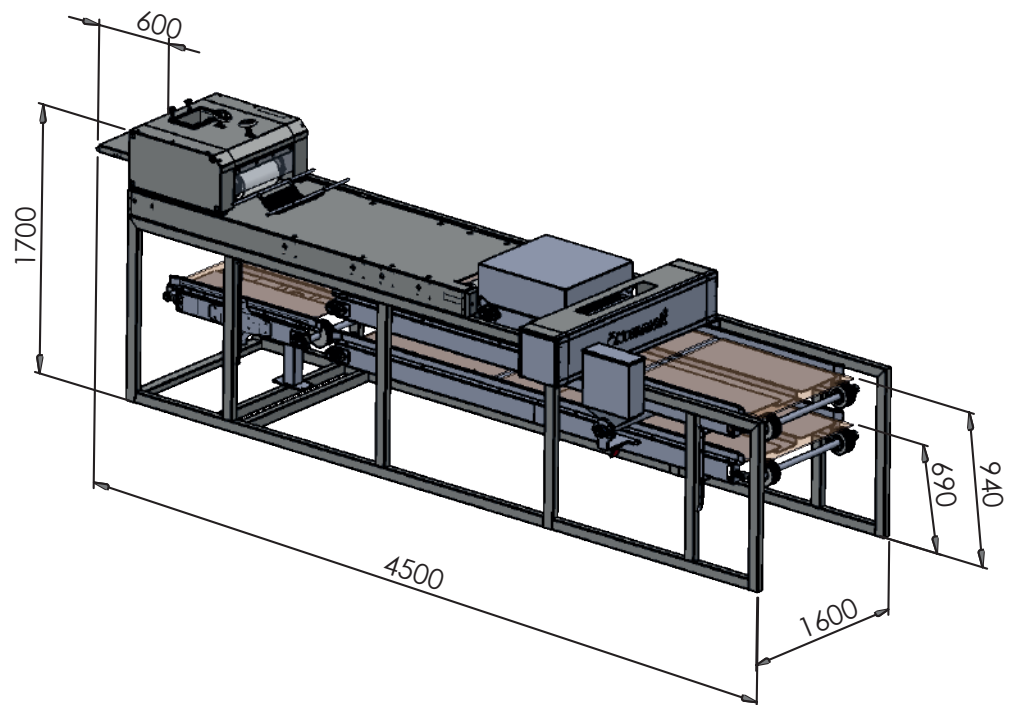

	1600 mm
	4500 mm
	1700 mm





RBT SERIES

robotics





Ekmek Yükleme Boşaltma Robotu Robotized Bread Loader & Unloader



RBT 1800

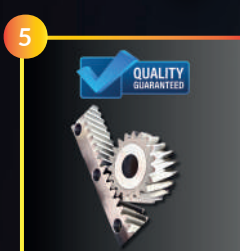
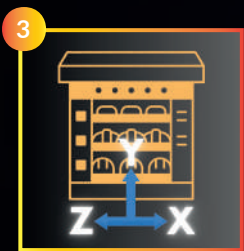

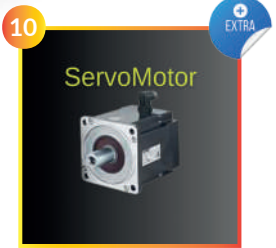
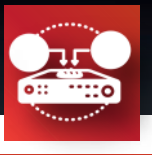

1 120-180-240 Katlı Fırınlar İçin İdealdir **2** A-(Ön Yükleme), B-(Ana Kürek),C-(Boşaltma), Şeklinde 3 İstasyondan Oluşmaktadır **3** 3 Eksende Hareket Etme **4** Tamamiyle Paslanmaz Şase ve Paneller **5** Önder® Tasarım, Helix Asansör Tekerler, Sayesinde, Hareketlerde Sarsın Olmaz **6** "Horn Head®", Küreğin Kafa Kısmı Girişte ve Çıkışta Aşağı-Yukarı Hareket Etmesi Sayesine; Band Ömrü Uzar - İçeride Ürün Bırakmayı Önler **7** Çoklu Nokta Güvenlik Sistemi, 2 Kademeli Motor Frenleri - Çevre Hareket Sensörleri - Hareket Sesli Uyarı - Bakım ve Güvenlik Stoperleri **8** PLC , Dokunmatik Ekran **9** 7/24, Küreğe Uzaktan Müdahale İmkani **10** Su Püskürtme Sistemi (+) **11** Otomatik Fırın İçini Süpürme Sistemi(+)**12** Servo Motor(+)

1 suitable for deck ovens 120-180-240 width **2** A-(Pre-Loader), B-(Main Loader),C-(Unloader),3 different stations **3** motorized motion in 3 dimension **4** stainless steel finish structure & panels **5** thanks to Önder® design helix gears, rails & rollers on the lift, minimum move-vibration **6** "Horn Head®" moves down and up during loading, unloading operation. It offers a longer lifetime for belt, avoids to drop any product in deck such **7** multi point safety system: dual motor brakes – motion sensors – motion alarming – bottom safety stoppers for maintenance – environment safety panels **8** PLC , touch screen panel **9** 7/24 online connection with loader, for support and update **10** automatic water spraying system(+)**11** automatic vacuum cleaner for cleaning deck inside(+)**12** Servo Motors(+)

1 apto para hornos de cubierta de 120-180-240 de ancho **2** A-(pre-cargador), B-(cargador principal), C-(descargador), 3 estaciones diferentes **3** moción motorizada en 3 dimensiones **4** estructura y paneles de acero inoxidable **5** gracias a engranajes de cremallera , ruedas y barra diseñadas por Önder® en elevador, permiten mínima vibración en movimientos **6** "Horn Head®" la cabeza se mueve hacia abajo y arriba a lo largo de la operación de cargar, descargar en función de alarga la vida útil de cinta, no dejar ningún producto dentro de horno **7** sistema de seguridad multipunto: doble frenos de motor, sensores de moción, alarmas de movimiento, soportes de seguridad abajo para mantenimiento, paneles de seguridad en torno **8** PLC, panel táctil **9** 7/24, conexión Internet con cargador para asistencia **10** automático sistema de rociador de agua(+)**11** aspiradora automática para limpiar el interior de cámara(+)**12** servo motores(+)

1 convient aux fours à sole de largeur 120-180-240 **2** A-(pré-chargeur), B-(chargeur principal), C-(déchargeur), 3 stations différentes **3** mouvement motorisé en 3 dimensions **4** structure et panneaux en acier inoxydable **5** grâce aux engrenages, roues et barre conçus par Önder® dans l'ascenseur, ils permettent un minimum de vibrations dans les mouvements **6** "Horn Head®" la tête descend et monte tout au long de l'opération de chargement, déchargement jusqu'à prolonger la durée de vie utile de la courroie, ne laisser tomber aucun produit sur le chargeur **7** système de sécurité multipoint : doubles freins moteurs, détecteurs de mouvement, alarmes de mouvement, supports de sécurité en dessous pour la maintenance, panneaux de sécurité autour **8** PLC écran tactile **9** 7/24, Internet connexion avec chargeur pour assistance **10** système automatique de pulvérisation d'eau(+)**11** aspirateur automatique pour nettoyer l'intérieur de la chambre(+)**12** servomoteurs(+)

1 geeignet für etagenöfen mit einer breite von 120-180-240 **2** A-(vorladegerät),B-(hauptladegerät), C-(entladegerät), 3 verschiedene stationen **3** motorisierte bewegung in 3 dimensionen **4** struktur und panele aus edelstahl **5** dank önder®design der zahnäder und rollen am lift, minimale vibrationen **6** „HORN HEAD®“ bewegt sich während des lade- und entladevorgangs nach unten und oben. Es bietet eine längere lebensdauer des bandes und verhindert, dass produkte über den lader fallen. **7** mehrpunkt-sicherheitsystem:2 motorbremsen – bewegungssensoren – bewegungsalarm – sicherheitsstopper für wartung – sicherheitsgitterplatten **8** PLC touchscreen-panel **9** 7/24 online-verbinding mit lader, zur unterstützung und aktualisierung **10** automatisches wassersprühsystem(+)**11** automatischer staubsauger zum reinigen des innen(+)**12** servomotoren(+)

1 adatto per forni a piani di larghezza 120-180-240 **2** A-(precaricatore), B-(caricatore principale), C-(scaricatore), 3 diverse stazioni **3** movimento motorizzato in 3 dimensioni **4** struttura e pannelli in acciaio inossidabile **5** grazie ad ingranaggi, ruote e barra progettati da Önder® nell'ascensore, consentono vibrazioni minime nei movimenti **6** "Horn Head®" la testa si muove su e giù durante tutta l'operazione di carico, scarico a prolungare la vita utile del nastro, non far cadere alcun prodotto sopra il caricatore **7** sistema di sicurezza multipunto: doppi freni motore, sensori di movimento, allarmi di movimento, supporti di sicurezza inferiori per la manutenzione, pannelli di sicurezza intorno **8** PLC pannello touch **9** 7/24, Internet collegamento con caricatorie per assistenza **10** sistema automatico di nebulizzazione dell'acqua (+)**11** aspiratore automatico per la pulizia interna della camera(+)**12** servomotori(+)

1 adequado para fornos de convés com largura de 120-180-240 **2** A-(pré-carregador), B-(carregador principal), C-(descarregador), 3 estações diferentes **3** movimento motorizado em 3 dimensões **4** estrutura e painéis em aço inoxidável **5** graças às engrenagens, rodas e barra projetadas por Önder® no elevador, permitem vibração mínima nos movimentos **6** "Horn Head®" o cabeçote se move para baixo e para cima durante toda a operação carregando, descarregando para prolongar a vida útil da correia, não deixar cair nenhum produto em cima da carregadeira **7** sistema de segurança multiponto: freios motores duplos, sensores de movimento, alarmes de movimento, suportes de segurança abaixo para manutenção, painéis de segurança ao redor **8** PLC painel touch **9** 7/24, Internet conexão com carregador para assistência **10** sistema automático de pulverização de água(+)**11** aspirador automático para limpar o interior da câmara (+)**12** servo motores(+)

1 120-180-240 szélességű fedélzeti kemencékhez alkalmas **2** A-(Pre-Loader), B-(Main Loader),C-(Unloader),3 különböző állomás **3** motorizált mozgás 3 dimenzióban **4** szerkezet és panelek rozsdamentes acélból **5** az Önder®-nek köszönhetően Tervezett fogaskerekek és görgők az emelőn, minimális vibráció **6** Horn Head®" le-és felfelé mozog be- és kirakodás közben. Hosszabb élettartamot kínál a hevedernek, elkerüli, hogy a termék leessen a rakodóra **7** Többpontos biztonsági rendszer: 2 motorfék – mozgásérzékelők – mozgásriasztó – biztonsági ütközők a karbantartáshoz – biztonsági rács panelek **8** PLC , érintőképernyős panel **9** 7/24 online kapcsolat rakodó, támogatáshoz és frissítéshez **10** automatikus vízpermetező rendszer(+)**11** automata porszívó a fedélzet belső tisztításához(+)**12** Servo Motors(+)

1 подходит для ярусных печей шириной 120-180-240 **2** A-(предварительный загрузчик), B-(основной загрузчик),C-(разгрузчик),3 различных станции **3** моторизованное движение в 3-х измерениях **4** конструкция и панели изготовлены из нержавеющей стали **5** спасибо Önder® конструкция шестерен и роликов на подъемнике, минимальная вибрация **6** «Horn Head®» перемещается вниз и вверх во время погрузки и разгрузки. Обеспечивает более длительный срок службы ремня, позволяет избежать падения продуктов на погрузчик **7** Многоточечная система безопасности:2 тормоза двигателя – датчики движения – сигнализация движения – предохранительные стопоры для обслуживания – панели безопасности **8** ПЛК, сенсорная панель **9** 24 онлайн-соединения с погрузчик, для поддержки и обновления **10** автоматическая система распыления воды(+)**11** автоматический пылесос для внутренней очистки палубы(+)**12** Серводвигатели(+)





SLS SERIES



bread slicers





Setüstü Ekmek Dilimleme - Tabletop Bread Slicer



SLS 100

MANUAL

AUTO

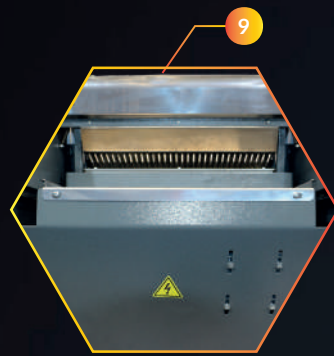

🇹🇷 1 Manuel ve Otomatik 2 Model 2 Ekmek Poşetleme Aparatı 3 Otomatik Kapak(otomatik) 4 Paslanmaz İç Sacı, Boyalı Dış Gövde 5 Kırıntı Toplama Çekmecesi 6 Frenli Döner Tekerli Stand 7 Dayanıklı Palanmaz Bıçaklar, 8 - 24 mm Kalınlık Aralığı 8 Renk Seçenekleri 9 Kalibreli Arka Baskı 10 Teflon Kaplı Bıçak(+) 11 120 Volt Soket 12 Kolay Kullanım ve Bakım

🇺🇰 1 manual & automatic in 2 models 2 ergonomic packaging apparatus 3 close & start , safety cover with switch (only auto) 4 inner place made of stainless steel,electrostatic painted steel structure 5 crumb drawer 6 trolley with swivel wheels with brake(+) 7 reinforced stainless steel blades 8 color options 9 consistent pressure & speed in operation 10 teflon coated blades(+) 11 120 volt plug-in(4) 12 easy to use & clean

🇪🇸 1 manual y automático en 2 modelos 2 ergonómico aparato de embalaje 3 cerrar y encender, cubierta de seguridad con interruptor (solo automático) 4 interior de acero inoxidable, estructura de acero pintado electrostático 5 cajón de migas 6 carro con ruedas giratorias frenadas(+) 7 durables cuchillas de acero inoxidable 8 opciones de color 9 consistente presión y velocidad en la operación 10 cuchillas recubiertas de teflón(+) 11 conexión 120v(+) 12 fácil de usar y limpiar



Cortadoras De Pan Sobre Mesa - Trancheuses À Pain De Table - Tisch Brotshneidemaschinen - Tagliapane Da Banco-Fatiadores de Pão De Mesa Asztali Kenyérszeletelő Gép-Настольные хлеборезки - قواطع زبخل عي طقت



1 manuel et automatique en 2 modèles 2 dispositif d'emballage ergonomique 3 fermeture et marche, couvercle de sécurité avec interrupteur (automatique uniquement) 4 intérieur en acier inoxydable, structure en acier peint électrostatique 5 récupérateur de miettes 6 chariot avec roues pivotantes freinées(+) 7 lames en acier durable inoxydable 8 options de couleur 9 pression constante et vitesse de fonctionnement 10 lames recouvertes de téflon(+) 11 connexion 120V 12 facile à utiliser et à nettoyer

1 manuell und automatisch in 2 modellen ergonomisches verpackungsgerät schliessen und starten, sicherheitsabdeckung mit schalter (nur automatisch) 4 innenraum aus edelstahl, struktur aus elektrostatisch lackiertem stahl 5 krümelshublade 6 wagen mit schwenkrädern mit bremse(+) 7 verstärkte edelstahlmesser 8 farboptionen 9 konstanter druck und geschwindigkeit im betrieb 10 teflonbeschichtete klingen(+) 11 120v-stecker(+) 12 einfach zu bedienen und zu reinigen

1 manuale e automatico in 2 modelli 2 dispositivo di imballaggio ergonomico 3 chiudi e accendi, coperchio di sicurezza con interruttore (solo automatico) 4 interno in acciaio inossidabile, struttura in acciaio verniciato elettrostatico 5 raccogli briciole 6 carrello con ruote girevoli frenate(+) 7 lame in acciaio inossidabile resistente 8 opzioni di colore 9 pressione costante e velocità di funzionamento 10 lame rivestite in teflon(+) 11 connessione 120v 12 facile da usare e da pulire

1 manual e automático em 2 modelos 2 dispositivo de embalagem ergonômico 3 fecha e liga, tampa de segurança com interruptor (apenas automático) 4 interior em aço inox, estrutura em aço com pintura eletrostática 5 coletor de migalhas 6 carrinho com rodas giratórias freiadas(+) 7 lâminas em aço inox duráveis 8 opções de cores 9 pressão consistente e velocidade na operação 10 lâminas revestidas de teflon(+) 11 conexão 120V 12 fácil de usar e limpar

1 kézi és automata 2 modellben 2 ergonomikus csomagolóberendezés 3 zárás és indítás, biztonsági burkolat kapcsolóval (csak automata) 4 belső hely rozsdamentes acélből, elektrosztatikusan festett acél szerkezet 5 morzsafiók 6 kocsis forgó kerekkel fékkel(+) 8 színválaszték 9 konzisztens nyomás és működési sebesség 10 teflon bevonatú pengék(+) 11 120V-os csatlakozó (4) 12 könnyen használható és tisztítható

1 ручное и автоматическое в 2 моделях 2 эргономичное упаковочное устройство 3 закрытие и запуск, защитная крышка с выключателем (только автоматический) 4 внутреннее отделение из нержавеющей стали, стальная конструкция, окрашенная в электростатическом поле 5 выдвижной ящик для крошек 6 тележка с поворотными колесами с тормозом(+) 7 усиленные лезвия из нержавеющей стали 8 варианты цвета 9 постоянное давление и скорость в работе 10 лезвия с тефлоновым покрытием(+) 11 розетка на 120 V(+) 12 простота в использовании и чистке

1 ذالوفلا نم عونصم يلخاد ناكم 4 (طوقف يئاقولت) احتفبب نام اطخ، لي غشتلا ادبو قال غ: 3 حيرم ئيب عت زا هج 2 نيزار ط يف أيكيتاموتو أو أيودي 1 قيق دلا تضف نم 1 أدصلل مواقملا ذالوفلا نم ؤز زم تارفش 7 (+) لم ارف عم قراود تالاج عب قبر ع 6 تاتف جرد 5 ئيكيتاموتو الاء اب رطكل اب يلطم يذالوف لك يه، أدصلل مواقملا فيظن تلو او ما دخستلا الاء لس 12 (+) تلو ف 120 س باق 11 (+) نولفتل اب ئيلطم تارفش 10 لي غشتلا يف عرسو قسانتم طغض 9 ناولال تاراخي 8

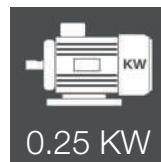
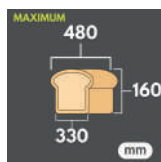
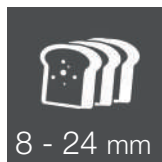
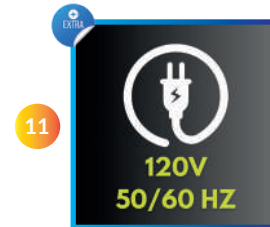

MANUAL

AUTO

	678 mm
	646 mm
	637 mm

	609 mm
	646 mm
	637 + (100) mm

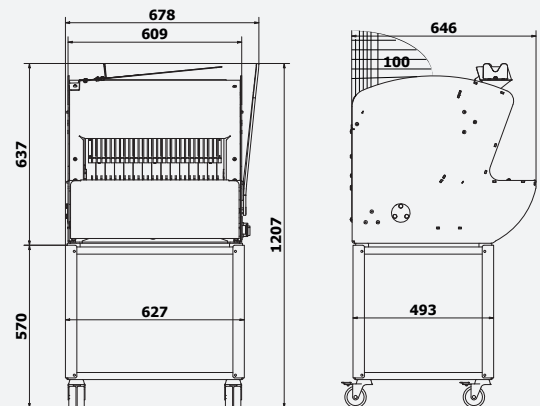



SLS 500

MANUAL

AUTO

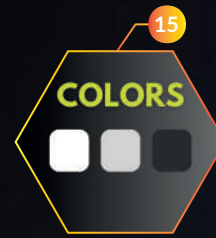

1 Manuel ve Otomatik 2 Model 2 Ekmek Poşetleme Aparatı 3 Otomatik Seri ya da Manuel Çalışma Versiyonu 4 Paslanmaz İç Sacı, Boyalı Dış Gövde 5 Kırıntı Toplama Çekmecesi 6 Frenli Döner Tekerli 7 Dayanıklı Palanmaz Bıçaklar, 8 - 24 mm Kalınlık Aralığı 8 3 Devir Hız (hızlı-normal-yavaş) 9 Kalibreli Arka Baskı 10 Teflon Kaplı Bıçak(+) 11 120 Volt Soket(+) 12 Harici Poşetleme(+) 13 Harici Bıçak Yağlama(+) 14 Aynı Makine 2'li Dilimleme(+) 15 Renk Seçeneği 16 Klolay Kullanım ve Bakım

1 manual & automatic in 2 models 2 ergonomic packaging apparatus 3 close & start, safety cover with switch (only auto) or manual/auto continual slicing feature without cover 4 inner place made of stainless steel, electrostatic painted steel structure 5 crumb drawer 6 swivel wheels with brake 7 reinforced stainless steel blades (8-24mm range thickness) 8 3 x speed (fast-normal-slow) 9 consistent pressure & speed in operation 10 teflon coated blades(+) 11 120 volt plug-in(+) 12 external air blower for bags(+) 13 external blade lubricant(+) 14 slicing in 2 thickness in one machine (+) 15 color options 16 easy to use & clean

1 manual y automático en 2 modelos 2 ergonómico aparato de embalaje 3 cerrar y encender, cubierta de seguridad con micro (solo automático) o alimentación continua para rebanar (versión 2) 4 interior de acero inoxidable, estructura de acero pintado electrostático 5 cajón de migas 6 ruedas giratorias frenadas(+) 7 durables cuchillas de acero inoxidable 8 3 x velocidad (rapido-normal-lento) 9 consistente presión y velocidad en la operación 10 cuchillas recubiertas de teflón(+) 11 conexión 120v(+) 12 externo soplador de aire para bolsas de pan(+) 13 externo aparato para lubricación de cuchillas(+) 14 rebanar 2 grosores distintos con una maquina 15 opciones de color 16 fácil de usar y limpiar



Trancheuses À Pain - Brotschneidemaschinen - Tagliapane - Fatiadores de Pão Kenyérszeletelő Gép- Хлебoreзки - زببخ عاطق



1 manuel et automatique en 2 modèles **2** dispositif d'emballage ergonomique **3** fermer et allumer, couvercle de sécurité avec micro (automatique uniquement) ou alimentation continue pour trancher (version 2) **4** intérieur en acier inoxydable, structure en acier peint électrostatique **5** tiroir à miettes **6** roues pivotantes freinées **7** acier inoxydable durable lames **8** 3 x vitesse (rapide-normal-lent) **9** pression et vitesse de fonctionnement constantes **10** lames recouvertes de téflon(+) **11** connexion 120V(+) **12** souffleur d'air externe pour sacs à pain(+) **13** lubrifiant externe pour lame(+) **14** trancher 2 épaisseurs différentes avec une machine(+) **15** options de couleurs **16** facile à utiliser et à nettoyer

1 manuell und automatisch im 2 modellen **2** ergonomisches verpackungsgerät **3** schließen und starten, sicherheitsabdeckung mit schalter (nur automatisch) oder manuelle/automatische kontinuierliche schneidefunktion ohne abdeckung **4** innenraum aus edelstahl, elektrostatisch lackierte stahlstruktur **5** krümelschublade **6** räder mit bremsen **7** verstärkte edelstahlmesser (8-24 mm dicke) **8** 3-fache geschwindigkeit (schnell-normal-langsam) **9** gleichmäßiger druck und gleichmäßige geschwindigkeit im betrieb **10** teflonbeschichtete klingen(+) **11** 120V steckdose(+) **12** externes luftgebläse für beutel(+) **13** externes klingenschmiermittel(+) **14** schneiden in 2-facher dicke in einer maschine(+) **15** farboptionen **16** einfach zu verwenden und zu reinigen

1 manuale e automatico in 2 modelli **2** dispositivo di confezionamento ergonomico **3** chiudi e accendi, coperchio di sicurezza con micro (solo automatico) o alimentazione continua per affettare (versione 2) **4** interno in acciaio inox, struttura in acciaio verniciato elettrostatico **5** cassetto raccogli briciole **6** ruote piroettanti frenate **7** acciaio inox resistente lame **8** 3 x velocità (veloce-normale-lenta) **9** pressione e velocità costanti durante il funzionamento **10** lame rivestite in teflon(+) **11** connessione 120V(+) **12** ventilatore d'aria esterno per sacchetti di pane(+) **13** lubrificante lama esterno(+) **14** tagliare 2 spessori diversi con una macchina(+) **15** opzioni colori **16** facile da usare e da puliredispositivo di imballaggio

1 manual e automático em 2 modelos **2** dispositivo de embalagem ergonômico **3** fechar e ligar, tampa de segurança com micro (apenas automático) ou alimentação contínua para fatiar (versão 2) **4** interior em aço inoxidável, estrutura em aço com pintura eletrostática **5** gaveta de migalhas **6** rodas giratórias com freio **7** aço inoxidável durável lâminas **8** 3 x velocidade (rápido-normal-lento) **9** pressão e velocidade consistentes na operação **10** lâminas revestidas de teflon(+) **11** conexão 120V(+) **12** soprador de ar externo para sacos de pão(+) **13** lubrificante externo da lâmina(+) **14** cortar 2 espessuras diferentes com uma máquina(+) **15** opções de cores **16** fácil de usar e limpar

1 kézi és automatikus, 2 modellben **2** ergonomikus csomagolóberendezés **3** azonnal záró és indító biztonsági fedél kapcsolóval (csak automatikus mód esetén) vagy fedél nélkül manuális/automatikus folyamatos szeletelési lehetőség **4** belső tér rozsdamentes acélből, elektrostatikusan festett acélváz **5** morzsa gyűjtőláda **6** kormánykerekek fékkel **7** erősített rozsdamentes acél penge (8-24mm vastagságú szeletekhez) **8** 3 sebesség (gyors-normál-lassú) **9** állandó nyomás és sebesség működés közben **10** teflon bevonatú penge(+) **11** 120 voltos dugós csatlakozó(+) **12** külső levegőfúvó tasakokhoz(+) **13** külső penge kenőanyag(+) **14** 2 vastagságú szeletelés egy gépben(+) **15** színválaszték **16** könnyű használat és tisztítás

1 ручной и автоматический режим в 2 моделях **2** эргономичное упаковочное устройство **3** закрытие и запуск, защитная крышка с переключателем (только в автоматическом режиме) или функция непрерывной ручной/автоматической нарезки без крышки **4** внутреннее отделение из нержавеющей стали, стальная конструкция, окрашенная в электростатическом поле **5** выдвижной ящик для крошек **6** колеса с тормозом **7** усиленные лезвия из нержавеющей стали (толщина 8-24 мм) **8** 3 скорости (быстрая-нормальная-медленная) **9** постоянное давление и скорость в работе **10** лезвия с тефлоновым покрытием(+) **11** розетка на 120V(+) **12** внешний вентилятор для пакетов(+) **13** внешняя смазка лезвий(+) **14** нарезка на 2 толщины в одной машине(+) **15** варианты цвета **16** простота в использовании и чистке

1 ليخ ادلا ن الكفملا **4** اطغ نودب يي ئاقلتلا/يوديلا رمدسمل عيطقتلا فريم وا (طوق يي ئاقلت) حانغسب نام اطغ ،لي غشيتلا عذبو قالغ **3** حيرم ئيب عت زاج **2** نيزار طيف ايكي تياموتو او يودي **1** يداع - عيرس) عيرسلا 3x (لم 8-24 لكيس) اصللل مواقملا ذالوفلا نم فز زم تارفش **7** لم ارف عم تال ج **6** تاتف جرد **5** ئيكي تاتسالا اابر لظلاب يلطم يذالوف لكيه ، اصللل مواقملا ذالوفلا نم عون صن 2 x كمسب عيطقت **14** (+) فرشلل ئي جراح مي حشرت قدام **13** (+) بئاق حلل جراح او ه خاف نم **12** (+) تالوف 120 سبقم **11** (+) نولفتلاب ئي لطم تارفش **10** لي غشيتلا ي ف قسبتم عرسو طغض (ءيطب - **9** عيطب - **8** 3 x سرعة (المراسم-الطبيعية-البيضاء) **7** سرعة (المراسم-الطبيعية-البيضاء) **6** سرعة (المراسم-الطبيعية-البيضاء) **5** سرعة (المراسم-الطبيعية-البيضاء) **4** سرعة (المراسم-الطبيعية-البيضاء) **3** سرعة (المراسم-الطبيعية-البيضاء) **2** سرعة (المراسم-الطبيعية-البيضاء) **1** سرعة (المراسم-الطبيعية-البيضاء)

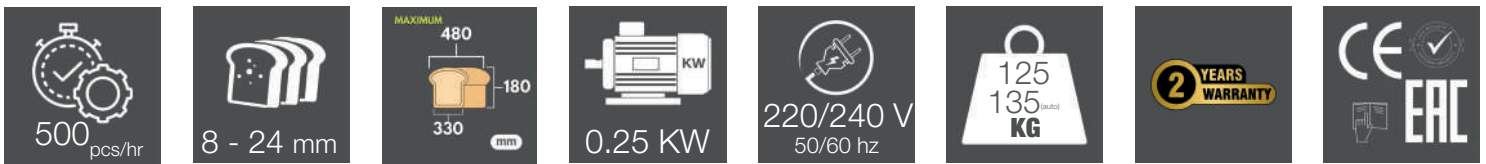
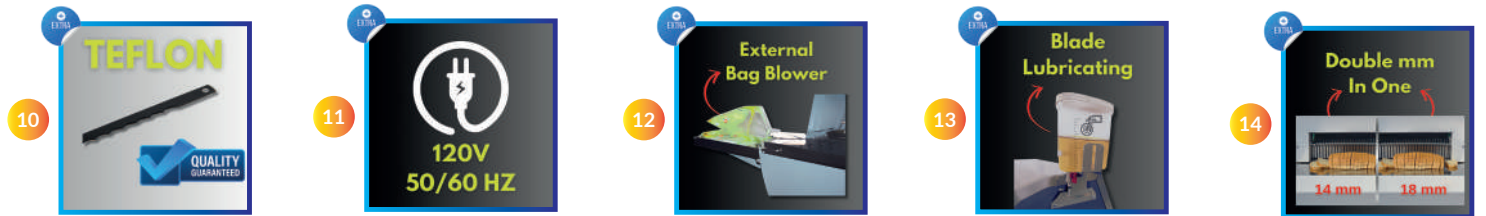

	MANUAL	AUTO
W	750 mm	610 mm
L	940 mm	940 mm
H	1220mm	1100 + (80) mm

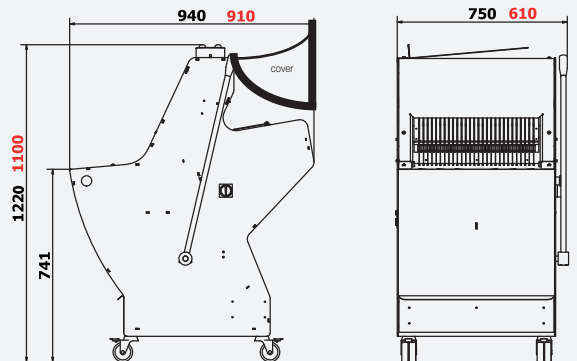



SLS 1000

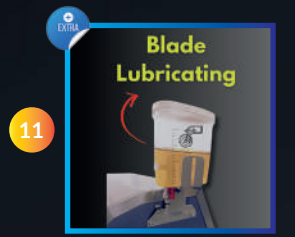

🇹🇷 1 Ayarlı Rampa Tip Ekmek Besleme 2 Pro Kontrol Paneli 3 Band Hızı ve Yükseklik Ayarı 4 Çıkışta Yatay Dikey Ekmek Hizalayıcıları 5 Kırıntı Toplama Çekmecesi 6 Frenli Döner Tekerli 7 Dayanıklı Palanmaz Bıçaklar, 8 - 24 mm Kalınlık Aralığı 8 Katlanır Hava Üfleme Poşetleme 9 Paslanmaz İç Sacı, Boyalı Dış Gövde 10 Teflon Kaplı Bıçak(+) 11 Harici Bıçak Yağlama(+) 12 Renk Seçeneği 13 Klolay Kullanım ve Bakım

🇬🇧 1 ramp with guide for bread feeding 2 PRO control panel 3 speed control for conveyor & tweak for belt's height level 4 horizontal/vertical guides at the output to align 5 crumb drawer 6 swivel wheels with brake 7 reinforced stainless steel blades (8-24mm range thickness) 8 integrated air blower for bags(foldable) 9 inner place made of stainless steel,electrostatic painted steel structure 10 teflon coated blades(+) 11 external blade lubricant(+) 12 color options 13 easy to use & clean

🇪🇸 1 rampa con guía al acceso 2 PRO panel de control 3 cinta transportadora con variador de velocidad y ajuste para el nivel de altura de la cinta arriba 4 guías horizontales y verticales a la salida en función de enfilar 5 cajón de migas 6 ruedas giratorias frenadas 7 durables cuchillas de acero inoxidable(8-24 mm rango de grosor) 8 integrado soplador de aire para bolsas de pan(plegable) 9 interior de acero inoxidable, estructura de acero pintado electrostático 10 cuchillas recubiertas de teflón(+) 11 externo aparato para lubricación de cuchillas(+) 12 opciones de color 13 fácil de usar y limpiar





Self Servis Ekmek Dilimleme - Self Service Bread Slicer



SLS 3000

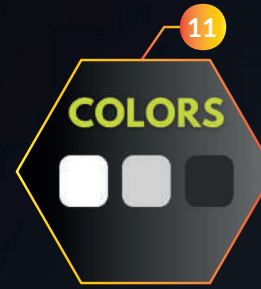

🇹🇷 **1**Self Servis Ekmek Dilimleme **2** 8 - 24 mm Arasında İstenilen Kalınlıkta Dilimleme **3**Disk Tip Döner Teflon Bıçak **4**Dokunmatik Ekran(adet - 1/2 kesim - mm ayarlama) **5**El ve Kapak Sensörleri Tam Güvenlik **6**Paslanmaz İç Sacı, Boyalı Dış Gövde **7**Poşet Askısı **8**Kırıntı Çekmecesi Poşetleme **9**Frenli Döner Tekerler **10**Ekmek Poşetleme Aparatı **11**Renk Seçeneği **12**120-220V Elektrik(+) **13**Kloday Kullanım ve Bakım

🇬🇧 **1**self service bread slicer for general use and super markets **2**free to slice between 8 -24 mm thickness **3**teflon coated circular disk **4**touch screen (pieces -½ slicing-tweak mm) **5**cover sensors and hand detectors for maximum safety **6**inner place made of stainless steel,electrostatic painted steel structure **7**bread pack hanger **8**crumb drawer **9**swivel wheels with brake**10**bread pack apparatus **11**color options **12**120-220V energy(+)**13**easy to use & clean

🇪🇸 **1**auto servicio cortadora de pan para uso general y supermercados **2**libertad en rebanar entre 8 -24 mm de grosor **3**teflonado disco circular **4**pantalla táctil (numero de PCS - ½ corte - regulador en mm) **5**sensores de cubierta con micro y detector de proximidad de mano para máxima seguridad **6**interior de acero inoxidable, estructura de acero pintado electrostático **7**aparato para colgar bolsa de pan **8**cajón de migas **9**ruedas giratorias frenadas**10**aparato para empaquetar pan **11**opciones de color **12**120-220V energia(+)**13**fácil de usar y limpiar



“SELF SERVICE” Cortadora De Pan - Trancheuses À Pain Brotschneidemaschinen - Tagliapane - Fatiadores De Pão Kenyérszeletelő Gép - Хлеборезки - زبخة عاطق

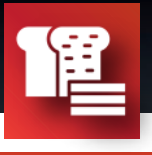

1 trancheuse à pain libre-service pour usage général et supermarchés **2** liberté de coupe entre 8 et 24 mm d'épaisseur **3** disque circulaire recouvert de téflon **4** écran tactile (nombre de pièces - 1/2 coupe - réglage en mm) **5** capteurs de plateau avec micro et détecteur de proximité manuel pour une sécurité maximale **6** acier inoxydable structure intérieure en acier peint électrostatique **7** dispositif de suspension pour sacs à pain **8** tiroir à miettes **9** roues pivotantes freinées **10** dispositif d'emballage du pain **11** options de couleurs **12** alimentation 120-220V(+) **13** facile à utiliser et à nettoyer

1 selbstbedienungs-brotschneidemaschine für den allgemeinen gebrauch und supermärkte **2** freies schneiden zwischen 8 und 24 mm dicke **3** teflonbeschichtete kreisförmige scheinbe **4** touchscreen (stücke-1/2 schneiden-optimieren mm) **5** abdeckungssensoren und handdetektoren für maximale sicherheit **6** innenraum aus edelstahl, struktur aus elektrostatisch lackiertem stahl **7** aufhänger für brotpackungen **8** krümelshublade **9** schwenkräder mit bremse **10** brotpackungsvorrichtung **11** farboptionen **12** 120-220V energie(+) **13** einfach zu verwenden und zu reinigen

1 affettapane self-service per uso generale e supermercati **2** libertà di taglio tra 8 e 24 mm di spessore **3** disco circolare rivestito in teflon **4** touch screen (numero PZ - 1/2 taglio - regolazione in mm) **5** sensori di piano con micro e rilevatore di prossimità mano per la massima sicurezza **6** acciaio inox struttura interna in acciaio verniciato elettrostatico **7** dispositivo per appendere il sacchetto del pane **8** cassetto raccogli briciole **9** ruote girevoli con freno **10** dispositivo per il confezionamento del pane **11** opzioni colori **12** alimentazione 120-220V(+) **13** facile da usare e da pulire

1 fatiador de pão self-service para uso geral e supermercados **2** liberdade no corte entre 8 -24 mm de espessura **3** disco circular revestido em teflon **4** tela touch screen (número de PCS - 1/2 corte - ajuste em mm) **5** sensores de deck com micro e detector de proximidade manual para máxima segurança **6** aço inoxidável interior, estrutura de aço com pintura eletrostática **7** dispositivo para pendurar sacos de pão **8** gaveta de migalhas **9** rodas giratórias com freio **10** dispositivo de embalagem de pão **11** opções de cores **12** 120-220V de potência(+) **13** fácil de usar e limpar

1 önkiszolgáló kenyérszeletelő általános használatra és szupermarketekhez **2** szabadon szeletelhető 8-24 mm vastagság között **3** teflon bevonatú kör alakú lemez **4** érintőképernyő (1/2 darab szeletelés-csípés mm) **5** fedél szenzorok és kézi detektorok a maximális biztonság érdekében **6** rozsdamentes acél belső hely elektrosztatikusan festett acélszerkezet **7** kenyércsomagtartó **8** morzsafiók **9** forgó kerekek fékkel **10** kenyércsomagoló berendezés **11** színválaszték **12** 120-220V energia(+) **13** könnyen használható és tisztítható

1 хлеборезка самообслуживания для общего пользования и супермаркетов **2** можно нарезать ломтики толщиной от 8 до 24 мм **3** круглый диск с тефлоновым покрытием **4** сенсорный экран (нарезка кусочками - 1/2 мм, регулировка мм) **5** крышка датчиков и ручные датчики для максимальной безопасности **6** внутреннее место изготовлено из нержавеющей стали, стальная конструкция, окрашенная в электростатическом поле **7** Вешалка для пакетов хлеба **8** Выдвижной ящик для крошек **9** Поворотные колеса с тормозом **10** Упаковщик хлеба **11** Варианты цвета **12** Энергия 120-220В(+) **13** Простота в использовании и чистке

1 عطق فسنن - عطق سمللاب لمعت تشاش **2** نولفسي تدا م يلم يرياد صرق **3** مم 8 - 24 **4** نولفسي تدا م يلم يرياد صرق **5** عطق فسنن - عطق سمللاب لمعت تشاش **6** نولفسي تدا م يلم يرياد صرق **7** نولفسي تدا م يلم يرياد صرق **8** نولفسي تدا م يلم يرياد صرق **9** نولفسي تدا م يلم يرياد صرق **10** نولفسي تدا م يلم يرياد صرق **11** نولفسي تدا م يلم يرياد صرق **12** نولفسي تدا م يلم يرياد صرق **13** نولفسي تدا م يلم يرياد صرق

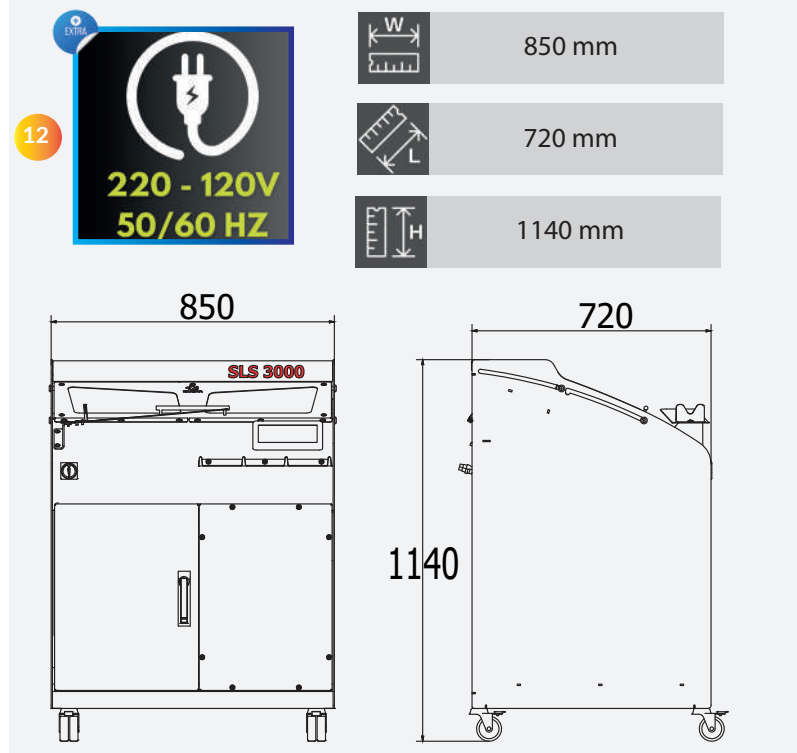
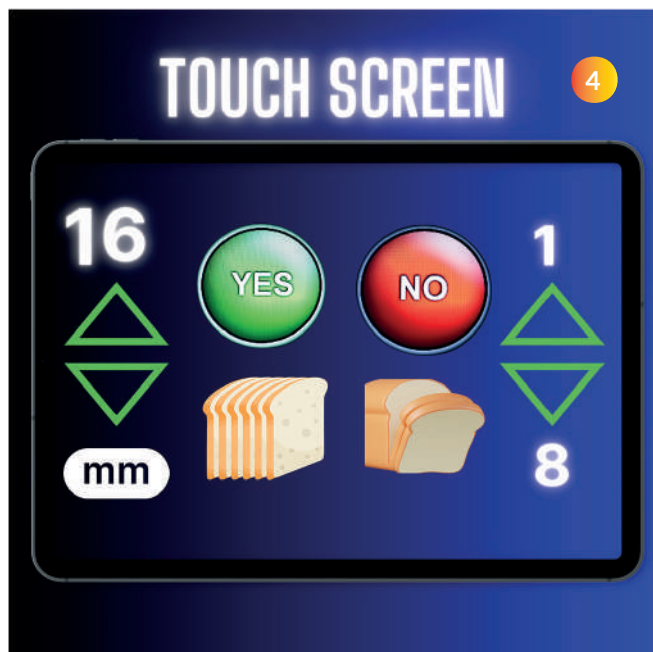
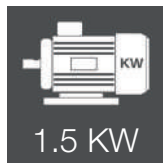
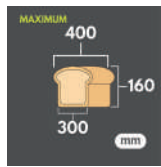
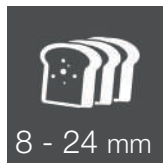

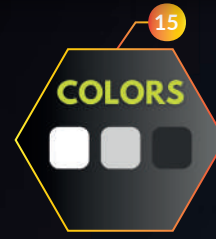

🇹🇷 **1** Süper Marketler İçin **2** Ekmek Poşetleme Aparatı **3** Manyetik Sensörlü Ön Kapak **4** Paslanmaz İç Sacı, Boyalı Dış Gövde **5** Kırıntı Toplama Çekmecesesi **6** Frenli Döner Tekerli **7** Dayanıklı Palanmaz Bıçaklar, 8 - 24 mm Kalınlık Aralığı **8** Manyetik Sensörlü Arka Koruma Kapağı **9** Otomatik Devirli Baskı **10** Teflon Kaplı Bıçak(+) **11** 120 Volt Soket(+) **12** Harici Poşetleme(+) **13** Harici Bıçak Yağlama(+) **14** Aynı Makine 2'li Dilimleme(+) **15** Renk Seçeneği **16** Kolay Kullanım ve Bakım

🇬🇧 **1** Self Service bread slicer for supermarkets **2** ergonomic packaging apparatus **3** Auto magnetic front safety cover with switch **4** inner place made of stainless steel, electrostatic painted steel structure **5** crumb drawer **6** swivel wheels with brake **7** reinforced stainless steel blades (8-24mm range thickness) **8** Auto magnetic back safety cover with switch **9** Automatic pressure & speed adjustment system according to bread **10** teflon coated blades(+) **11** 120 volt plug-in(+) **12** external air blower for bags(+) **13** external blade lubricant(+) **14** slicing in 2 thickness in one machine (+) **15** color options **16** easy to use & clean

🇪🇸 **1** Self Service tipo cortadora de pan para súper mercados **2** ergonómico aparato de embalaje **3** auto-magnética cubierta de seguridad con micro a la salida **4** interior de acero inoxidable, estructura de acero pintado electrostático **5** cajón de migas **6** ruedas giratorias frenadas **7** durables cuchillas de acero inoxidable (8-24 mm) **8** auto-magnética cubierta de seguridad con micro a la entrada **9** Auto sistema para ajustar presión y velocidad según pan **10** cuchillas recubiertas de teflón(+) **11** conexión 120v(+) **12** externo soplador de aire para bolsas de pan(+) **13** externo aparato para lubricación de cuchillas(+) **14** rebanar 2 grosores distintos con una maquina **15** opciones de color **16** fácil de usar y limpiar



Self Service

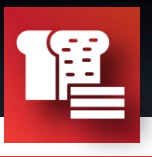

1 Trancheuse à pain de type SELF SERVICE pour supermarchés **2** dispositif d'emballage ergonomique **3** couvercle de sécurité auto-magnétique avec micro sortie **4** intérieur en acier inoxydable, structure en acier peint électrostatique **5** tiroir à miettes **6** roues pivotantes freinées **7** lames en acier inoxydable durables (8-24 mm) **8** couvercle de sécurité auto-magnétique avec micro à l'entrée **9** Système automatique pour régler la pression et la vitesse en fonction du pain **10** Lames recouvertes de téflon(+) **11** Connexion 120v(+) **12** souffleur d'air externe pour sacs à pain(+) **13** dispositif externe pour lubrification de la lame(+) **14** tranchez 2 épaisseurs différentes avec une seule machine **15** options de couleurs **16** facile à utiliser

1 Selbstbedienungs-Brot Schneidemaschine für Supermärkte **2** Ergonomisches Verpackungsgerät **3** Automatisch magnetische vordere Sicherheitsabdeckung mit Schalter **4** Innenraum aus Edelstahl, Struktur aus elektrostatisk lackiertem Stahl **5** Krümelschublade **6** Schwenkräder mit Bremse **7** verstärkte Edelstahlklingen (8-24 mm Dicke) **8** Automatische magnetische vordere Sicherheitsabdeckung mit Schalter **9** Automatisches Druck- und Geschwindigkeitsanpassungssystem je nach Brot **10** teflonbeschichtete Klingen(+) **11** 120-Volt-Anschluss(+) **12** externes Luftgebläse für Beutel(+) **13** externes Klingenschmiermittel(+) **14** Schneiden in 2 Stärken in einer Maschine (+) **15** Farboptionen **16** einfach zu verwenden und zu reinigen

1 Affettatrice per pane tipo Self Service per supermercati **2** dispositivo di confezionamento ergonomico **3** coperchio di sicurezza automagnetico con micro uscita **4** interno in acciaio inox, struttura in acciaio verniciato elettrostatico **5** cassetto raccogli briciole **6** ruote piroettanti frenate **7** acciaio inox resistente lame **8** coperchio di sicurezza automagnetico con micro all'ingresso **9** sistema automatico per regolare pressione e velocità in base al pane **10** lame rivestite in teflon(+) **11** connessione 120V(+) **12** ventilatore d'aria esterno per sacchetti di pane(+) **13** lubrificante lama esterno(+) **14** tagliare 2 spessori diversi con una macchina(+) **15** opzioni colori **16** facile da usare e da pulire dispositivo di imballaggio

1 cortador de pão tipo Self Service para supermercados **2** dispositivo de embalagem ergonômico **3** tampa de segurança automagnética com micro saída **4** interior em aço inoxidável, estrutura em aço com pintura eletrostática **5** gaveta de migalhas **6** rodas giratórias com freio **7** aço inoxidável durável lâminas **8** tampa de segurança automagnética com micro na entrada **9** sistema automático para ajuste de pressão e velocidade de acordo com o pão **10** Lâminas revestidas de teflon(+) **11** conexão 120V(+) **12** soprador de ar externo para sacos de pão(+) **13** lubrificante externo da lâmina(+) **14** cortar 2 espessuras diferentes com uma máquina(+) **15** opções de cores **16** fácil de usar e limpar

1 Önkiszolgáló kenyérszeletelő szupermarketekhez **2** Ergonómikus csomagolóberendezés **3** Automatikus mágneses elülső biztonsági burkolat kapcsolóval **4** Rozsdamentes acél belső hely, elektrosztatikusan festett acél szerkezet **5** morzsafiók **6** Forgó kerekek fékkel kapcsolóval **9** Automatikus nyomás- és fordulatszám-beállító rendszer kenyér szerint **10** teflon bevonatú pengék (+) **11** 120 voltos dugaszolható (+) **12** külső légfúvó táskákhoz (+) **13** külső pengék-enőanyag(+)
14 2 vastagságban szeletelés egy gépben (+) **15** színválaszték **16** könnyen használható és tisztítható

1 Хлебозрезка самообслуживания для супермаркетов **2** Эргономичное упаковочное устройство **3** Автоматическая магнитная передняя защитная крышка с переключателем **4** внутреннее отделение из нержавеющей стали, стальная конструкция, окрашенная в электростатическом поле **5** выдвижной ящик для крошек **6** поворотные колеса с тормозом **7** усиленные ножи из нержавеющей стали (толщина диапазона 8-24 мм) **8** Автоматическая передняя защитная крышка с переключателем **9** Автоматическая система регулировки давления и скорости в зависимости от хлеба **10** лезвия с тефлоновым покрытием(+) **11** розетка на 120 В(+) **12** внешний вентилятор для пакетов(+) **13** внешняя смазка лезвий(+) **14** нарезка на 2 толщины в одной машине (+) **15** варианты цвета **16** простота в использовании и чистке

10 TEFLON
QUALITY GUARANTEED

11 120V
50/60 HZ

12 External
Bag Blower

13 Blade
Lubricating

14 Double mm
In One
14 mm 18 mm

638 mm

715 + 125 mm

1247 mm

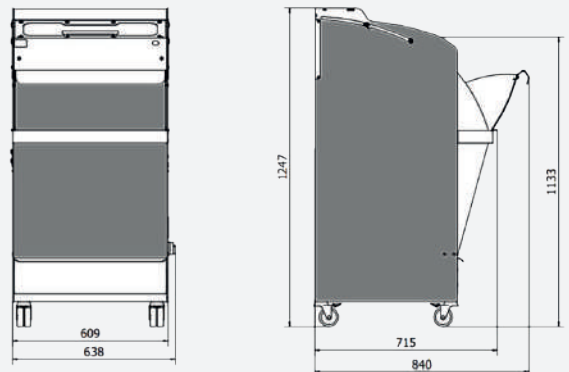



SPMX SERIES

mixers



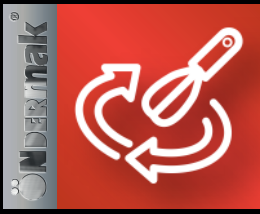

SPMX



MINI



* SPMX Mini
Analog Control
Start/Stop
Speed Control









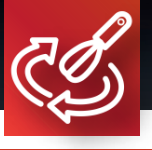



- 1 Digital kontrol - Digital Control - Digitale Steuerung - digitális vezérlés - цифровое управление
- 2 Plastik üst gövde - Plastic top cover - Cubierta plastica arriba - couvercle en plastique - Plastikabdeckung - műanyag fedél - cobertura in plastica - пластиковая крышка
- 3 Paslanmaz ızgara - Stainless steel cover with safety switch - Rejilla de Inox con micro - Griglia in acciaio inossidabile con sicurezza automatica- Rejilla en acier inoxydable avec sécurité automatique - Rejilla de aço inoxidável com segurança automática - Edelstahl-Schüsselabdeckung mit automatischem Sicherheitsschalter - Нержавеющая стальная крышка для миски с автоматическим предохранительным переключателем - Rozsdamentes acél tál fedél automatikus biztonsági kapcsolóval
- 4 Paslanmaz kazan,çapa - Stainless steel bowl and fork - Caldera y aparatos de INOX - Caldaia ed elettrodomestici in acciaio inox - Chaudière et électroménager en inox - Caldeira e eletrodomésticos em inox - Edelstahl-Schüssel und Gabel - Нержавеющая стальная миска и вилка - Rozsdamentes acél tál és villa
- 5 Stoper ve teker - Stopper & wheels - Pies para fijar y ruedas - piedini da fissare e ruote - pieds à fixer et roulettes - pies para fijar y ruedas - Stopper und Räder - стопор и колеса - stopper és kerekek
- 6 Boyalı demir gövde - Body is made of painted iron -Estructura de hierro pintado - Struttura in ferro verniciato - Structure en fer peint- Estrutura de ferro pintadaDie Struktur besteht aus lackiertem Eisen.-Конструкция сделана из окрашенного железа - A szerkezet festett fémből készült
- 7 Yavaş devir - Slow speed/timer adjustment - Ajusto lento y temporizador - Impostazione lenta e timer - Réglage lent et minuterie - onfiguração lenta e temporizador - Langsame Geschwindigkeits-/Timeranpassung - Регулировка медленной скорости/таймера - Lassú sebesség/időzítő beállítás
- 8 Kazan sağ/sol dönüş - Bowl rotation left/right - Schüsselrotation links/rechts - Вращение миски влево/вправо - Tál forgatás balra/jobbra
- 9 Hızlı Devir - Fast speed/timer adjustment - Ajusto rapido y temporizador - Impostazione rapida e timer - Réglage rapide et minuterie- Configuração rápida e temporizador - schnelle Geschwindigkeits-/Timeranpassung - Быстрая настройка скорости/таймера - Gyors sebesség/időzítő beállítás
- 10 Otomatik mod/uyarı ve arıza alarımları - Auto mode and error alarms - Uso automático y alarmas de errores - Allarmi automatici di utilizzo ed errore- Alarmes automatiques d'utilisation et d'erreur - Alarmes automáticos de uso e erro - Automatischer Modus/Fehleralarme - Автоматический режим/сигналы об ошибках - Automatikus üzemmód/hiba riasztások



Mélangeurs A Spirale - Spiralmischer - Impastatrice A Spirale
 Amassadeira Espiral - Spirális Keverő
 Спиральный миксер - قماود طالخ



MODEL	 kg	 kg	 lt.	 kw	 kw	 kg	 W	 L	 H	 rpm	 V/hz
SPMX-MINI	5	9	12	0,37		35	300	500	450	105/210/14	220V 50hz
SPMX-25	25	40	70	1.5 / 2.5	0.75	225	530	980	1100	105/210/14	400V 3NPE 50hz
SPMX-40	35	60	100	2.5 / 3.5	0.75	310	640	1080	1300	105/210/14	400V 3NPE 50hz
SPMX-60	65	100	170	3.5 / 5.5	1.1	450	750	1400	1400	105/210/14	400V 3NPE 50hz
SPMX-80	80	130	220	5.5 / 7.5	1.1	530	850	1500	1500	105/210/14	400V 3NPE 50hz
SPMX-120	125	200	340	7.5 / 11	1.5	800	950	1600	1600	105/210/14	400V 3NPE 50hz
SPMX-150	150	250	350	7.5 / 11	1.5	900	1030	1700	1700	105/210/14	400V 3NPE 50hz

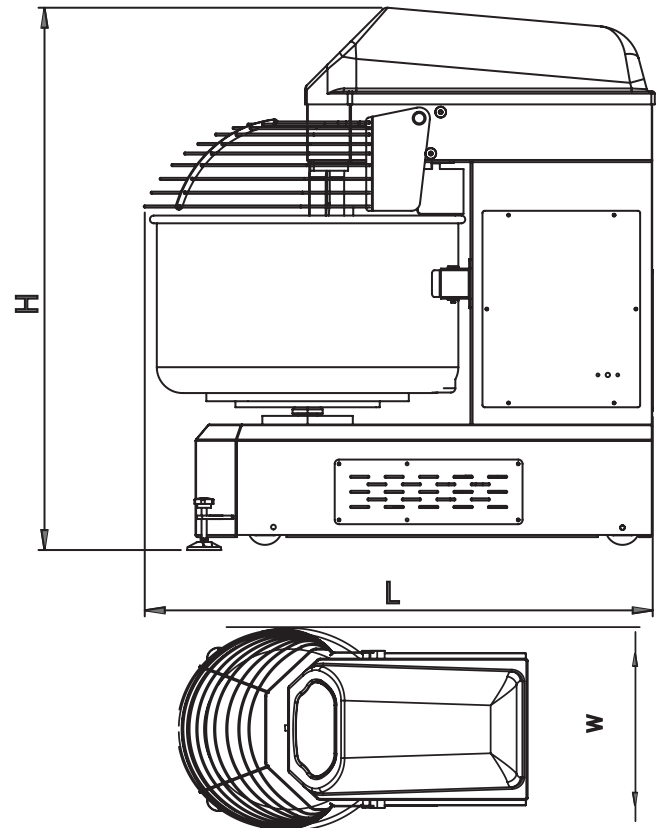
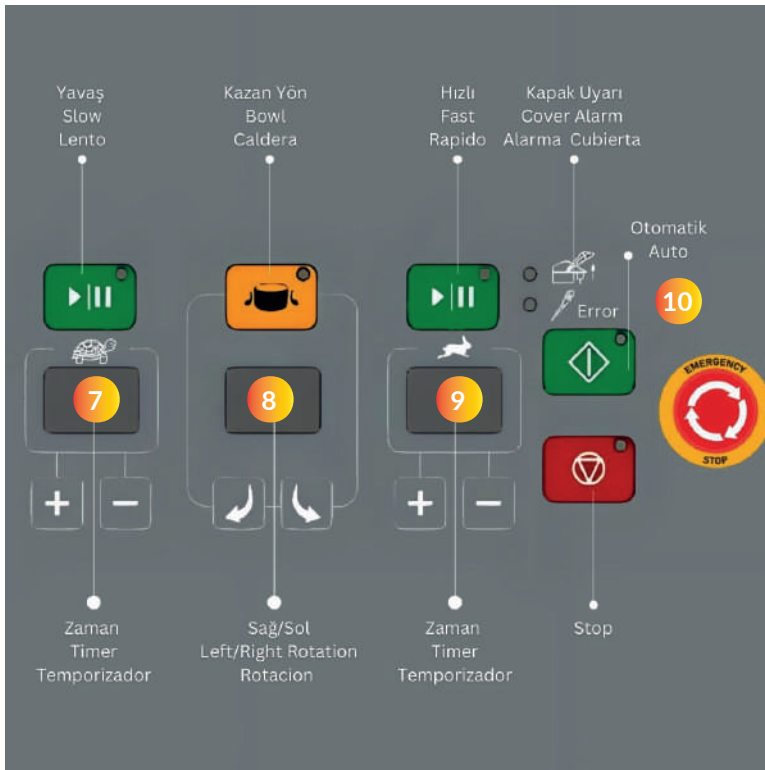
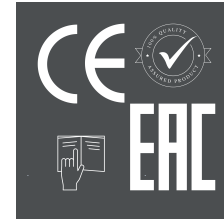
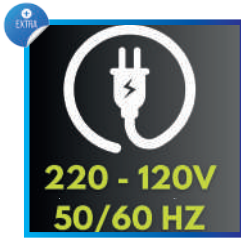



PLMX SERIES



planetary





PLM 20



PLM 40
PLM 60



PLM 80



analog control

- Zaman Ayarı
- 2 Devir
- Hiz Kontrol (+)
- Manuel Kazan Lift
- Güçlü Motor

- Minuterie
- 2 x Vitesse
- Contrôle de vitesse (+)
- Levage manuel
- Rotation puissante

- Cronômetro
- 2 x Velocidade
- Controle de velocidade (+)
- Elevador Manual
- Rotação poderosa

- تقويم لـ
- عرس 2 x
- عرس لـ في مكح لـ
- يودي لـ ع لـ
- يوق نارود

- Timer
- 2 x speed
- Speed Control (+)
- Manual Lift
- Powerful RPM

- Timer
- 2 x Geschwindigkeit
- Geschwindigkeitsregelung (+)
- Manueller Aufzug
- Kraftvolle Rotation

- Időzítő
- 2x sebesség
- Sebességszabályozás (+)
- Kézi emelő
- Erőteljes forgás

- Temporizador
- 2 x velocidad
- Control De Velocidad (+)
- Elevación Manual
- Potente RPM

- Timer
- 2 velocità
- Controllo della velocità (+)
- Sollevamento manuale
- Rotazione potente

- Таймер
- 2 x Скорость
- Контроль скорости (+)
- Ручной подъемник
- Мощное вращение



Mélangeurs Planétaires - Planetenmischer
 Impastatrici Planetarie - Misturadores Planetários
 بلكاوكل طالخ - Планетарный миксер

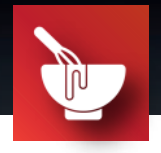

MODEL	kg	kg	adet	lt.	KW	KG	W	L	H	Q	V/hz
PLM-20	4	6	40	20	0,75	80	660	500	760	300x300	400V 3NPE 50hz
PLM-40	7	10	60	40	1.5 / 2.2	230	630	910	1370	400x400	400V 3NPE 50hz
PLM-60	10	15	120	60	1.5 / 2.2	250	630	920	1370	430x470	400V 3NPE 50hz
PLM-80	16	24	150	80	3.0	410	680	940	1600	500x500	400V 3NPE 50hz

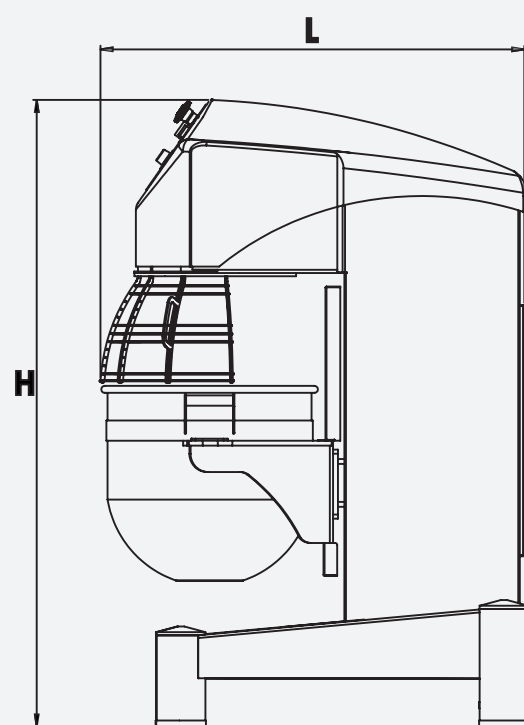
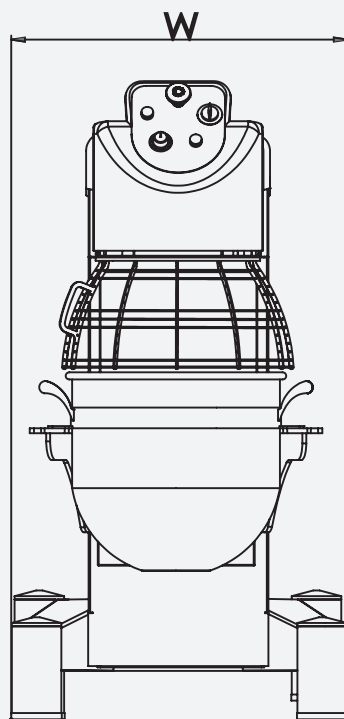
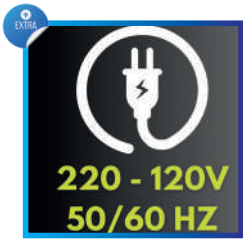



DNF SERIES

rotary ovens





1 Paslanmaz Aspiratör 2 Paslanmaz İç ve Dış Şase 3 Ergonomik Kapı 4 Temperli Cam ve Kolay Açılır Kapı Tertibatı 5 Elektro Mekanik Kontrol Panel 6 Paslanmaz Giriş Rampa 7 Burlör Dahil 8 Dinamik Hava Sirkülasyonu İyi Pişme 9 Döner Tabla Sistemi 10 Paslanmaz, Sağlam Cehennemlik 11 Yüksek Buhar Gücü 12 Yüksek İzolasyon 13 Riello Burlör(+) 14 Dokunmatik Kontrol Paneli(+)

1 high-power, stainless steel hood 2 stainless steel inner & outer structure 3 door gaskets in stainless steel and silicone rubber against air gaps 4 tempered glass and easy open/close door handle 5 electro-mechanic control panel 6 stainless steel ramp for trolley 7 burner included 8 dynamic and stable air flow for perfect baking 9 turn table rotation system 10 durable stainless steel furnace 11 high performance steam generators 12 armored structure and isolated body 13 Riello Burner(+) 14 Touch Control(+)

1 efectiva campana de INOX 2 paneles interior y exteriores de INOX 3 puerta de INOX, con la goma solida para aislamiento, no fuga de aire 4 manija sencilla y vidrio templado en puerta 5 electro-mecánico control de panel 6 rampa de INOX para carros 7 quemadura incluida 8 dinámica y estable circulación de aire para perfecta cocción 9 plataforma giratoria 10 durable cámara de combustión de INOX 11 eficacia en vaporizadores 12 fortalecida estructura, aislada firme 13 "Riello" quemadura (+) 14 pantalla táctil(+)

1 hotte efficace en acier inoxydable 2 panneaux intérieurs et extérieurs en acier inoxydable 3 porte en acier inoxydable, avec caoutchouc solide pour l'isolation, aucune fuite d'air 4 poignée simple et verre trempé sur la porte 5 panneau de commande électromécanique 6 rampe en acier inoxydable pour chariots 7 brûleur inclus 8 circulation d'air dynamique et stable pour une parfaite cuisson 9 plateforme rotative 10 chambre de combustion INOX durable 11 efficacité des vaporisateurs 12 structure renforcée, isolation ferme 13 Brûleur « Riello »(+) 14 écran tactile(+)





EMF SERIES

deck ovens

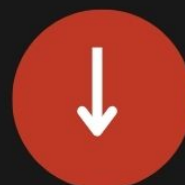
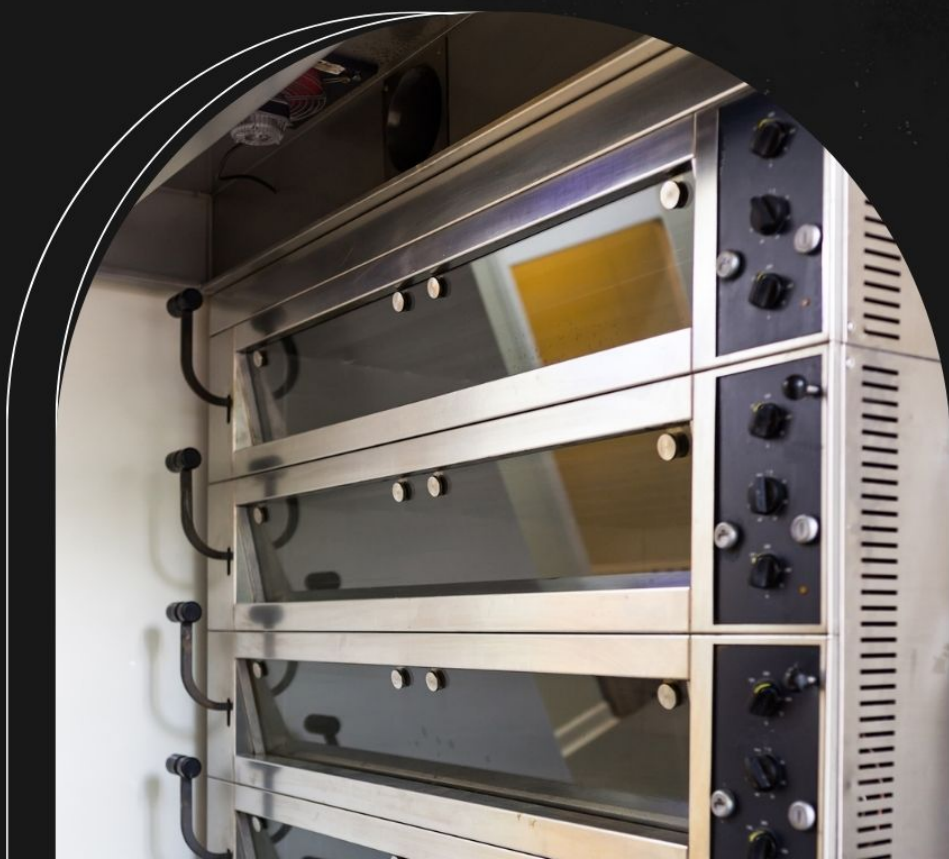



EMC SERIES



Digital Control



Touch Control

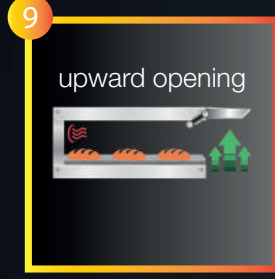
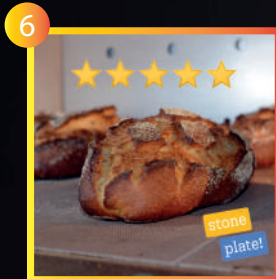
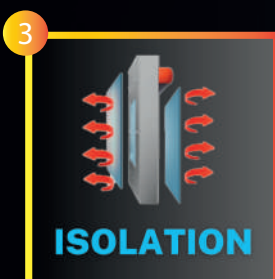
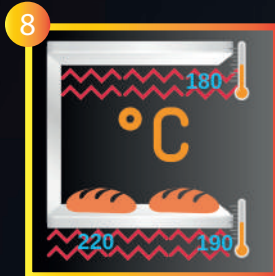
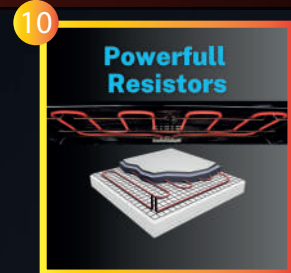
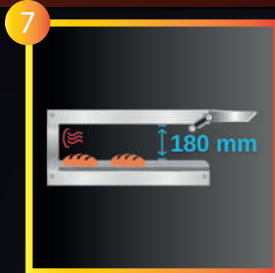
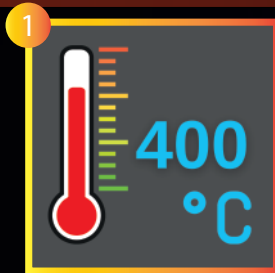



EMF S3 / M3 / L3

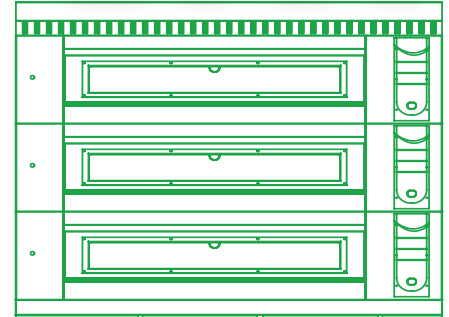

EMF S2 / M2 / L2

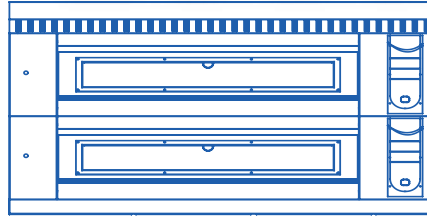

EMF S1 / M1 / L1

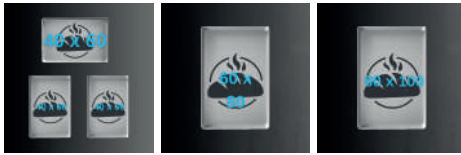
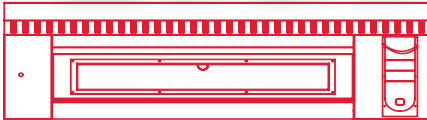

STANDARD



hood
aspiradora
davlumbaz

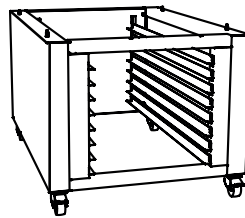

tray holder
soporte de bandejas
alt baza

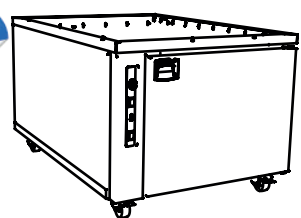

prover chamber
camara de ferment.
fermente odası

Model	Nr. Deck Nr. Pisos Kat Sayısı	Inner Oven Size Interior Dimension - mm Fırın Kat İçi Ebat		Exterior Oven Size Exterior Dimension - mm Fırın Dış Ebat			Deck Height Alto Camara Kat Yüksekliği mm	Installed Power Energía Instalada Künlü Güç KW	Steamer Power Vaporizadora Buhar Jen. KW	Fermentation Fermentación Fermente Odası KW	Power Supply Eléctrica Elektrik KW
		W	L	W	L	H					
EMF-S1	1	95	100	1480	1260+400	400+640	180	14,0	1,5	4,5	400V50 Hz 3P+N+PE
EMF-S2	2			1480	1260+400	1600+640		28,0	1,5		
EMF-S3	3			1480	1260+400	2000+640		42,0	1,5		
EMF-M1	1	125	100	1780	1260+400	400+640		15,0	1,5		
EMF-M2	2			1780	1260+400	1600+640		30,0	1,5		
EMF-M3	3			1780	1260+400	2000+640		45,0	1,5		
EMF-L1	1	125	125	1780	1520+400	400+640		18,0	3,0		
EMF-L2	2			1780	1520+400	1600+640		36,0	3,0		
EMF-L3	3			1780	1520+400	2000+640		54,0	3,0		

Digital Control
(standard)

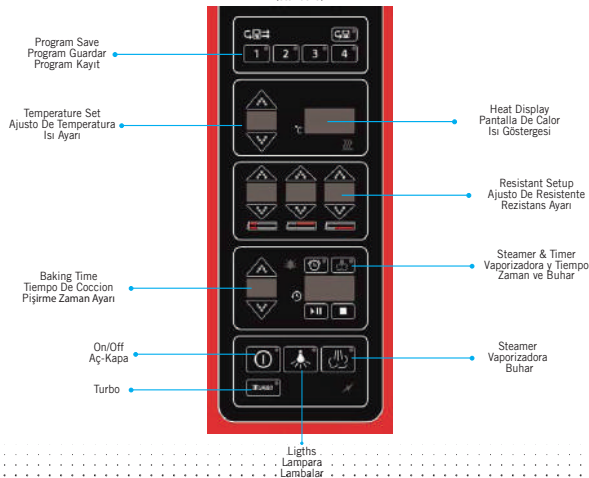

Hornos Modulares Electricos- Four Électrique Modulaire - Modularer Elektroofen Forno Elettrico Modulare - Forno Elétrico Modular - Moduláris Elektromos Sütő Модульная электрическая духовка - تادحو ويئابرهك نرف



1 400 C maksimum ısı 2 Elektrik kullanım 3 Tam izolasyon 4 Güçlü buhar verme ve turbo ısıtma 5 Paslanmaz paneller 6 Seramik taş taban 7 18 cm fırın iç yüksekliği 8 Alt, üst ve ön ayrı ısı ayarlama 9 Yukarı açılan paslanmaz kapak 10 Güçlü ve kaliteli rezistans 11 Temperli çift cam 12 Fırın içi aydınlatma



1 400 C° maximum 2 Electric energy in usage 3 High isolation 4 Powerful steamers and turbo heating feature (quick) 5 Entirely stainless steel structure 6 Ceramic stone plate 7 18 cm chamber/deck height 8 Independent temperature adjustment ceiling, floor and front 9 Upward doors 10 Premium quality heaters 11 Tempered double glass on door 12 Lights in chamber



1 400 C° máximo 2 Energía eléctrica al uso 3 Altísimo aislamiento 4 Vaporizadores poderosos y "Turbo" rapidez en alcanzar a grados determinados 5 Total estructura es acero inoxidable 6 Placa de suelo, hecha de piedra cerámica 7 Altura de cámara es 18 cm 8 Ajusto independiente en temperatura de suelo y techo, delante 9 Puertas abren hacia arriba 10 Primer calidad en calefactores 11 Puertas de doble vidrio 12 Lámparas en cámara



1 400 C° massimo 2 Energia elettrica da utilizzare 3 Altissimo isolamento 4 Potenti vaporizzatori e velocità "Turbo" nel raggiungimento di determinati gradi 5 La struttura totale è in acciaio inox 6 Piastra del pavimento, in pietra ceramica 7 L'altezza della camera è di 18 cm 8 Regolazione indipendente della temperatura del pavimento e del soffitto, anteriore 9 Porte con apertura verso l'alto 10 Riscaldatori di prima qualità 11 Porte in doppio vetro 12 Lampade nella camera



1 400 C° maximum 2 Énergie électrique à utiliser 3 Très haute isolation 4 Vaporisateurs puissants et vitesse « Turbo » pour atteindre certains degrés 5 La structure totale est en acier inoxydable 6 Plaque de sol en pierre céramique 7 La hauteur de la chambre est de 18 cm 8 Réglage indépendant de la température du sol et du plafond, avant 9 Les portes s'ouvrent vers le haut 10 Chauffages de première qualité 11 Portes doubles vitrées 12 Lampes dans la chambre



1 400 Co máximo 2 Energia eléctrica para usar 3 Isolamento muito alto 4 Vaporizadores potentes e velocidade "Turbo" para atingir determinados graus 5 Estrutura total em aço inoxidável 6 Placa de piso em pedra cerâmica 7 Altura da câmara de 18 cm 8 Ajuste independente da temperatura do chão e do teto, frontal 9 Portas abertas para cima 10 Aquecedores de primeira qualidade 11 Portas de vidro duplo 12 Lâmpadas na câmara



1 maximal 400 °c 2 elektrische energie im verbrauch 3 hohe isolierung 4 leistungsstarke dampfgarer und „turbo“-heizung, um schnell den gewünschten grad zu erreichen 5 komplett aus edelstahl gefertigte struktur 6 keramiksteinplatte 7 18 cm kammer-/deckhöhe 8 unabhängige temperatureinstellung an decke, boden und vorderseite 9 türen öffnen sich nach oben 10 heizung in premiumqualität komponenten 11 doppelglas an der tür 12 lichter in der kammer



1 400 C° maximum 2 Elektromos energia használatban 3 Magas szigetelés 4 Erőteljes gőzölők és "turbó" fűtés a gyors meghatározott fokozat eléréséhez 5 Teljes mértékben rozsdamentes acél szerkezet 6 Kerámia kőlap 7 18 cm-es kamra/fedélzeti minőség 8 Felülső mennyezet 9 Felülső oldali hőfok 10 Felül ter komponensek 11 Dupla üveg az ajtón 12 Lámpák a kamrában



1 Максимум 400 С° 2 Используемая электрическая энергия 3 Высокая изоляция 4 Мощные пароварки и «турбо» нагрев для быстрого достижения определенной температуры 5 Конструкция полностью из нержавеющей стали 6 Плита из керамического камня 7 Высота камеры/яруса 18 см 8 Независимая регулировка температуры потолка, пола и передней стороны 9 Двери открываются вверх 10 Нагреватель высшего качества компоненты 11 Двойное стекло на двери 12 Свет в камере



1 نم لكهيه 2 ععيرس قددحم قچرد ىلا لوصولل "وبرت" نىخستو قىوق رابخ قزهج 3 ىلا لزع 4 قمدختسمل قىئابرمكلا ققاطلا 5 ىصقأ دحك قىوئىم قچرد 6 ىصقأ دحك قىوئىم قچرد 7 ىصقأ دحك قىوئىم قچرد 8 ىصقأ دحك قىوئىم قچرد 9 ىصقأ دحك قىوئىم قچرد 10 ىصقأ دحك قىوئىم قچرد 11 ىصقأ دحك قىوئىم قچرد 12 ىصقأ دحك قىوئىم قچرد



PMF SERIES

deck ovens





PMF SERIES

PMF 5G/E



5 X
40X60



DIGITAL CONTROL

standard



Model	PMF 5G	PMF 5E
W mm	850	850
L mm	1140	1140
H mm	91	85
D mm	1640	1580
M2	1.2	1.2
Tray / Bandeja Nr. Tava Adet	5	5
Tray Bandeja Dim. Tava Ebat mm	400 x 600	400 x 600
Power Potencia Güç KW	0,62 + 2.1*	7.5 + 2.1*
Thermal Power T. Potencia Isıl Güç Kcal/Kw	12.0 / 14.0	6.0 / -
Kg	205 + 50*	195 + 50*
Energy Energia	400Vac 50Hz (3PH+N+PE)	400Vac 50Hz (3PH+N+PE)

OVEN
HORNO
FIRIN

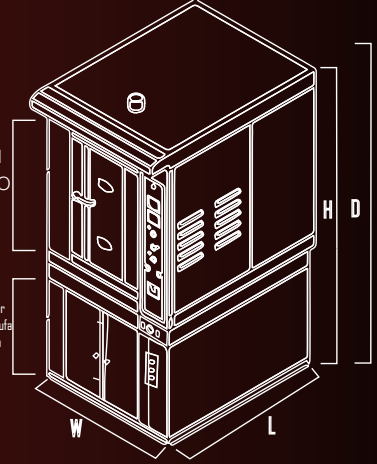

Stand - Base - F.Chamber
Soporte - Gabinete - Estufa
Stand - Baza - Mayalama

PMF 10G/E



9 X
40X60



DIGITAL CONTROL

standard



TOUCH

EXTRA

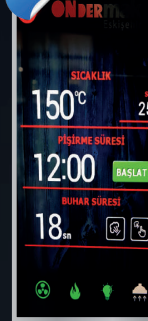

Model	PMF 10G	PMF 10E
W mm	850	850
L mm	1140	1140
H mm	1260	1200
D mm	2111	2005
M2	2.1	2.1
Tray / Bandeja Nr. Tava Adet	9	9
Tray Bandeja Dim. Tava Ebat mm	400 x 600	400 x 600
Power Potencia Güç KW	1.2 + 2.1*	15 + 2.1*
Thermal Power T. Potencia Isıl Güç Kcal/Kw	14.0 / 16.0	6.0 / -
Kg	295 + 50*	265 + 50*
Energy Energia	400Vac 50Hz (3PH+N+PE)	400Vac 50Hz (3PH+N+PE)

OVEN
HORNO
FIRIN

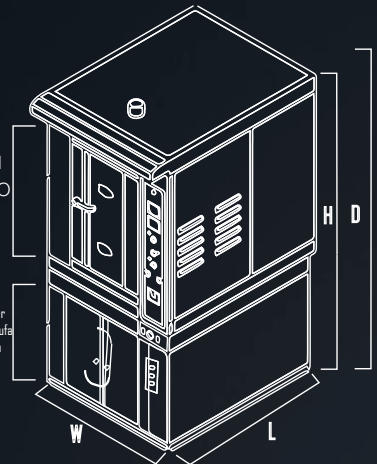

Stand - Base - F.Chamber
Soporte - Gabinete - Estufa
Stand - Baza - Mayalama



PMF 10DG/DE

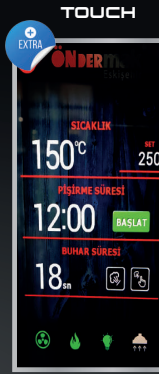
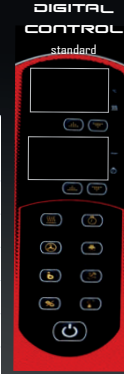

Model	PMF 10DG	PMF 10DE
W mm	1060	1040
L mm	1100	1040
H mm	1440	1445
D mm	2025	2030
M2	2.4	2.4
Tray / Bandeja Nr. Tava Adet	10	10
Tray Bandeja Dim. Tava Ebat mm	400 x 600	400 x 600
Power Potencia Güç KW	1.5+ 2.1*	16 + 2.1*
Thermal Power T. Potencia Isıl Güç Kcal/Kw	- / 17	- / 24
Kg	540 + 80*	440 + 80*
Energy Energja	400Vac 50Hz (3PH+N+PE)	400Vac 50Hz (3PH+N+PE)

OVEN
HORNO
FIRIN

Stand - Base - F.Chamber
Sopote - Gabinete - Estufa
Stand - Beza - Mayalama

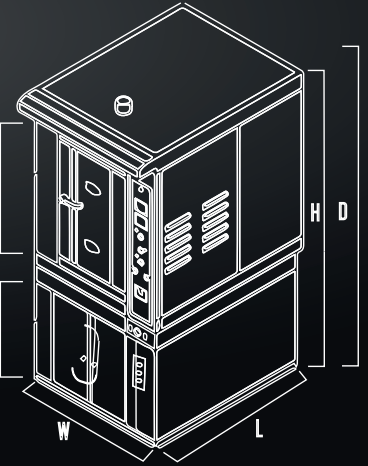

PMF DECO DESIGN 10DG/DE 10G/E





- » Ekmek ve ince mamuller için fırın
- » 3 farklı model
- » Gaz ya da elektrikli kullanım
- » Pişirme derecesi: 300°C max.
- » İç, dış yan paneller tamamı paslanmaz
- » Paslanmaz rezistans
- » Paslanmaz cehennemlik (gaz tip), atmosferik burlör
- » Yüksek izolasyon ile düşük yakıt tüketimi
- » Termal çift cam
- » Fırın içi aydınlatma
- » Kolay ve pratik kapı kolu
- » Montaj ve kurulum gerektirmez
- » Paslanmaz davlumbaz
- » Bacasız kullanım davlumbaz için saklanmış
- » Şelale sistema ile yüksek buhar
- » Çift hava fanı ile tam pişme
- » Dijital kontrol paneli
- » Dokunmatik ekran (opsiyonel)
- » Tekerli stand (opsiyonel)
- » Baza (opsiyonel)
- » Mayalama odası (opsiyonel)
- » Kolay kullanım ve bakım
- » Ce belgeli ürün
- » 2 yıl garanti



- » Designed for multi-purpose of baking
- » Available in 3 models (Gas, Electric, Rotary)
- » Electric or gas energy versions
- » Baking temperature: 300°C max.
- » Front, interior and lateral panels in stainless steel
- » The resistors in electric versions made of stainless steel
- » Atmospheric burner & stainless steel furnace in gas version
- » High isolation for energy saving
- » Door with tempered double glasses
- » Halogen lamp for the baking chamber
- » Handle for easy opening
- » Plug-in installation
- » Stainless steel hood
- » Fume extractor hidden in hood
- » Waterfall steam flowing for high steam
- » Double air heating fan in chamber
- » Digital control panel
- » Touch screen control panel (optional)
- » Stand with wheels (optional)
- » Base tray holder (optional)
- » Proofer chamber (fermentation) (optional)
- » Easy to care and clean
- » Ce certificated product
- » 2 years of warranty



- » Destinado para la variedad de cocción
- » Disponible de 3 modelos (Gas, Electrica, Rotativo)
- » Versión en eléctrico o gas
- » Temperatura: 300°C max.
- » Paneles exteriores, campana y interior de INOX
- » Resistan eléctrica de INOX
- » Quemadora atmosférica incluida, cámara de fuego de INOX en gas versión
- » Alto aislamiento para ahorro de energía
- » Puerto de doble thermal vidrios
- » Iluminación en cámara
- » Manilla robusta y fiable
- » Plug-in instalación, no requerido a montar
- » Campana de acero inoxidable
- » Descargador de humo, escondido en campana
- » Reforzado vaporizador para más denso en vapor
- » Doble turbinas de aire
- » Digital control panel
- » Pantalla táctil (opcional)
- » Soporte con ruedas (opcional)
- » Cabina de bandejas (opcional)
- » Cámara de estufa (fermentación) (opcional)
- » Fácil manejo y limpiar
- » Ce certificado
- » Garantía de 2 años



- » entwickelt für vielseitige backzwecke
- » erhältlich in 3 modellen (gas, elektro, rotation)
- » versionen mit elektro- oder gasenergie
- » backtemperatur: 300°C max.
- » front-, innen- und seitenwände aus edelstahl
- » die widerstände in elektrischen ausföhrungen aus edelstahl
- » atmosphärischer brenner & edelstahlöfen in gasversion
- » hohe isolierung zur energieeinsparung
- » tür mit gehärtetem doppelglas
- » halogenlampe für die backkammer
- » griff zum einfachen öffnen
- » plug-in-installation
- » haube aus edelstahl
- » rauchabsaugung in der haube versteckt
- » wasserfalldampf strömt für hohen dampf
- » doppelter luftheizventilator in der kammer
- » digitales bedienfeld
- » touchscreen-bedienfeld (optional)
- » ständer mit rollen (optional)
- » bodenwannenhalter (optional)
- » gärrkammer (gärung) (optional)
- » pflegeleicht und sauber
- » ce-zertifiziertes produkt
- » 2 jahre garantie



- » többcélú sütéshez tervezték
- » 3 modellben kapható (gáz, elektromos, forgó)
- » elektromos vagy gázenergiás változatok
- » sütési hőmérséklet: 300°C max.
- » előlső, belső és oldalsó panelek rozsdamentes acélból
- » az ellenállások elektromos kivitelben rozsdamentes acélból
- » atmoszférikus égő és rozsdamentes acél kemence gáz kivitelben
- » magas szigetelés az energiatakarékosság érdekében
- » edzett duplaüveges ajtó
- » halogén lámpa a sütőkamrához
- » fogantyú a könnyű nyitáshoz
- » plug-in telepítés
- » rozsdamentes acél búra
- » páraelszívó a motorháztetőbe rejtve
- » vízesés gőz áramlik a nagy gőzért
- » dupla légfűtő ventilátor a kamrában
- » digitális vezérlőpanel
- » érintőképernyős vezérlőpanel (opcionális)
- » kerek állvány (opcionális)
- » alaptálca tartó (opcionális)
- » pedukálókamra (erjedés) (opcionális)
- » könnyen kezelhető és tisztítható
- » ce minősítésű termék
- » 2 év garancia



- » Предназначен для универсальной выпечки.
- » Доступно 3 модели (газовая, электрическая, роторная).
- » Версии с электрической или газовой энергией
- » Температура выпекания: макс. 300°C.
- » Передние, внутренние и боковые панели из нержавеющей стали.
- » Резисторы в электрических версиях изготовлены из нержавеющей стали.
- » Атмосферная горелка и печь из нержавеющей стали в газовой версии
- » Высокая изоляция для энергосбережения
- » Дверь с двойным закаленным стеклом
- » Галогенная лампа для пекарной камеры
- » Ручка для легкого открытия
- » Установка плагина
- » Капот из нержавеющей стали
- » Вытяжка дыма спрятана в капоте
- » Пар водопада течет для высокой подачи пара
- » Двойной вентилятор нагрева воздуха в камере
- » Цифровая панель управления
- » Сенсорная панель управления (опция)
- » Подставка на колесах (опционально)
- » Держатель поддона (опция)
- » Расстойная камера (брожение) (опция)
- » Простота в уходе и чистке
- » Сертифицированный CE продукт
- » 2 года гарантии



DIGITAL CONTROL
standard



TOUCH SCREEN
extra

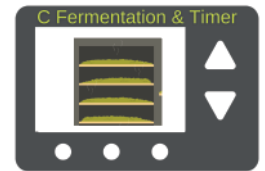
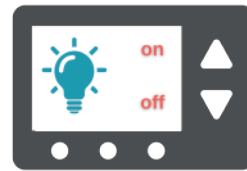
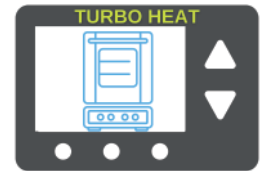
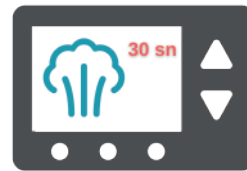
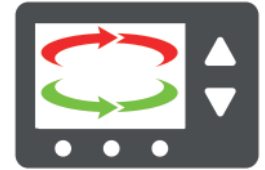
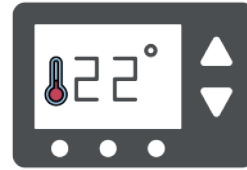



INDUSTRIAL SERIES

pro machines



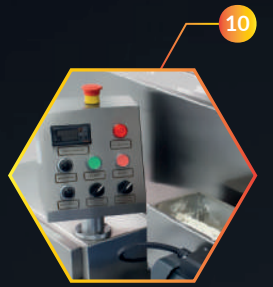
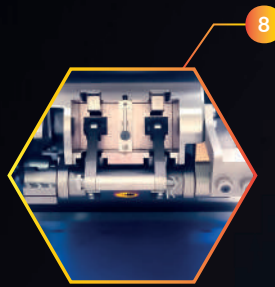
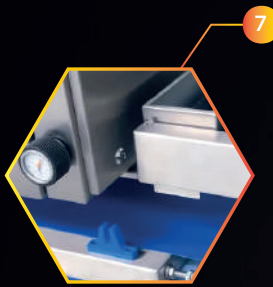

🇹🇷 1 210 Lt. Paslanmaz huni 2 Paslanmaz şase 3 Bağımsız koveyör hız ayarlı 4 Tekerler ile kolay hareket 5 Döküm I.kalite kesme sistemi 1-2-3 pistonlu 6 Otomatik unlama 7 Analog gramaj ve yay ayarı 8 Pro piston tertibatı 9 BEKA yağ pompası 7Lt., yağ seviyesi göstergeli 10 Analog kontrol, güvenlik tertibatı, hız ayarlı ve adet sayıcı 11 Teflon huni(+)

🇬🇧 1 stainless steel 210 lt .capacity hopper 2 complete stainless steel structure 3 independent conveyor belt with speed control 4 wheels , easy to move 5 Iron cast , premium quality suction system with 1,2,3 pistons 6 Automatic flour duster 7 Analog gram and spring adjustment 8 ultimate piston system 9 BEKA brand, oil pump , 7lt.capacity with level indicator 10 Analog control unit, safety switches, speed control and piece counter 11 Teflon coated hopper(+)

🇪🇸 1 Tolva de acero inoxidable, capacidad de 210 lt. 2 Estructura completa es de acero inoxidable 3 Cinta transportadora independiente con control de velocidad 4 Ruedas giratorias, para mover fácilmente 5 Sistema desarrollado de succión, hecho de fundido , modelos con 1,2,3 pistones 6 Harinadora automática 7 Análogo ajuste en gramaje y muelles 8 Avanzado sistema de pistones 9 BEKA marca, bomba de lubricación , capacidad 7 lt. , existe indicador de volumen 10 Análogo control panel, con control de velocidad, hay micros de seguridad, contador de piezas 11 Teflón recubierta tolva (+)

Diviseur Volumétrique - Volumetrischer Teigteiler - Divisore volumetrico

Dugattyús Osztó Gép - Divisor Volumétrico - Объемный делитель

ميم حجرجع لاء ءعاطق

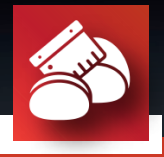

- 1 Trémie en acier inoxydable, capacité de 210 litres 2 Structure complète en acier inoxydable 3 Convoyeur indépendant avec contrôle de vitesse 4 Roues pivotantes pour un déplacement facile 5 Système d'aspiration développé, en fonte, modèles avec 1,2,3 pistons 6 Farineur automatique 7 Réglage analogique du poids et des ressorts 8 Système de piston avancé 9 Marque BEKA, pompe de lubrification, capacité 7 litres. , il y a un indicateur de volume 10 Panneau de commande analogique, avec contrôle de vitesse, il y a des micros de sécurité, un compteur de pièces 11 Trémie recouverte de téflon (+)

- 1 Trichter mit 210 l Fassungsvermögen aus Edelstahl 2 Komplette Struktur aus Edelstahl 3 Unabhängiges Förderband mit Geschwindigkeitsregelung 4 Räder, leicht zu bewegen 5 Eisenguss, hochwertiges Saugsystem mit 1,2,3 Kolben 6 Automatischer Mehlerstäuber 7 Analoge Gramm- und Federeinstellung 8 ultimatives Kolbensystem 9 Marke BEKA, Ölpumpe, 7 l Fassungsvermögen mit Füllstandsanzeige 10 Analoge Steuereinheit, Sicherheitsschalter, Geschwindigkeitsregelung und Stückzähler 11 Teflonbeschichteter Trichter(+)

- 1 Tramoggia in acciaio inox, capacità 210 lt. 2 Struttura completa in acciaio inossidabile 3 Nastro trasportatore indipendente con controllo della velocità 4 Ruote girevoli, per un facile spostamento 5 Sistema di aspirazione sviluppato, realizzato in fusione, modelli con 1,2,3 pistoni 6 Sfarinatore automatico 7 Adeguamento analogico del peso e delle molle 8 Sistema avanzato del pistone 9 Marchio BEKA, pompa lubrificazione, capacità 7 lt.è presente un indicatore del volume 10 Pannello di controllo analogico, con controllo della velocità, sono presenti micro di sicurezza, contapezzi 11 Tramoggia rivestita in teflon (+)

- 1 Depósito em aço inox, capacidade 210 lt. 2 Estrutura completa em aço inox 3 Correia transportadora independente com controle de velocidade 4 Rodas giratórias, para fácil movimentação 5 Sistema de sucção desenvolvido, em fundido, modelos com 1,2,3 pistões 6 Faradeira automática 7 Ajuste análogo de peso e molas 8 Sistema de pistão avançado 9 Marca BEKA, bomba de lubrificação, capacidade 7 lt., possui indicador de volume 10 Painel de controle analógico, com controle de velocidade, possui micros de segurança, contador de peças 11 Moega revestida em teflon (+)

- 1 rozsdamentes acél 210 l űrtartalmú tartály 2 komplett rozsdamentes acél szerkezet 3 független szállítószalag fordulatszám szabályozással 4 kerekek , könnyen mozgatható 5 vasöntvény , prémium minőségű szívórendszer 1,2,3 dugattyús 7 automatikus rugós dugattyús 8 KA márka, olajszivattyú , 7 literes űrtartalom szintjelzővel 10 Analóg vezérlőegység, biztonsági kapcsolók, fordulatszám szabályozás és darabszámláló 11 Teflon bevonatú garat (+)

- 1 нержавеющая сталь, емкость 210 л 2 полная конструкция из нержавеющей стали 3 независимая конвейерная лента с регулировкой скорости 4 колеса, легко перемещаются 5 чугунное литье, система всасывания высшего качества с 1,2,3 поршнями 6 автоматический мукоподсыпатель 7 аналоговая регулировка грамма и пружины 8 усовершенствованная поршневая система 9 марка ВЕКА, масляный насос, емкость 7 л с индикатором уровня 10 Аналоговый блок управления, предохранительные выключатели, контроль скорости и счетчик штук 11 Бункер с тefлоновым покрытием(+)

- 1 طفش ماظن ، رهزلا ديدج 2 عرسلا يف مكحتلا عم لقتسم لقان مازح 3 أصللل مواقلا ذالوفلا نم لماك لكيه 4 عرسلا يف مكحتلا عم لقتسم لقان مازح 5 عرسلا يف مكحتلا عم لقتسم لقان مازح 6 عرسلا يف مكحتلا عم لقتسم لقان مازح 7 عرسلا يف مكحتلا عم لقتسم لقان مازح 8 عرسلا يف مكحتلا عم لقتسم لقان مازح 9 عرسلا يف مكحتلا عم لقتسم لقان مازح 10 عرسلا يف مكحتلا عم لقتسم لقان مازح 11 عرسلا يف مكحتلا عم لقتسم لقان مازح

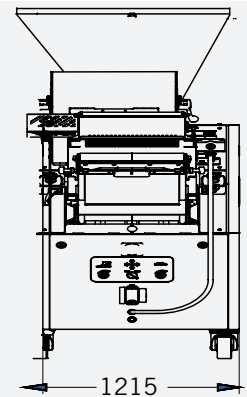
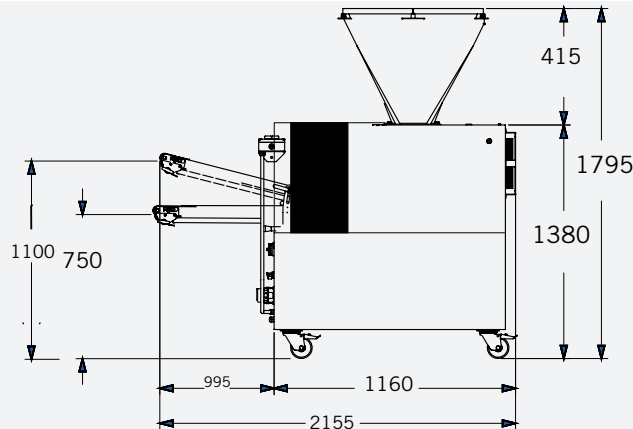
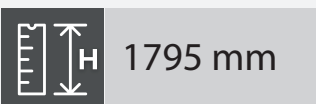
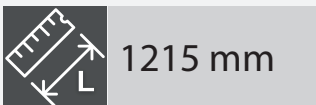
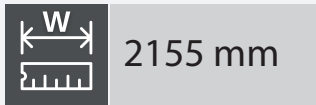
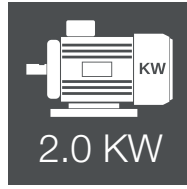



BMX SERIES



Mobile Spiral Mixer
Amasadora Espiral Movil



Elevator
Elevadora



Mobil Bowl
Caldera Movil



Portioner
Porcionador

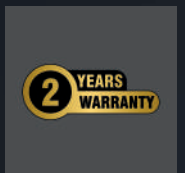

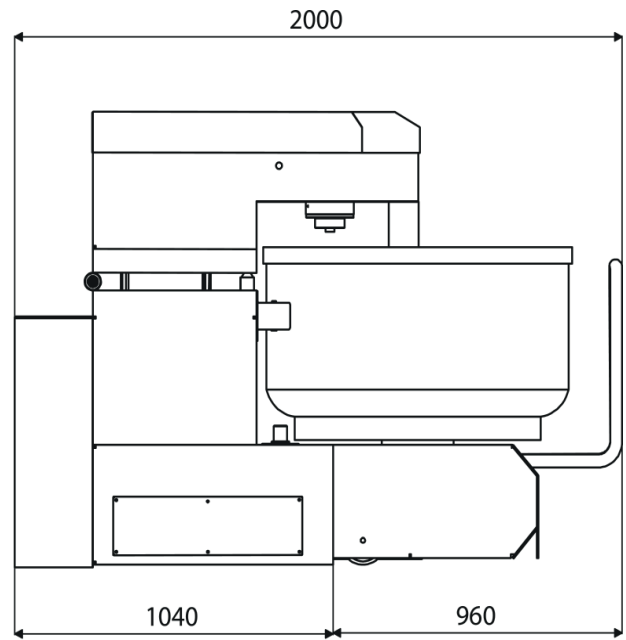
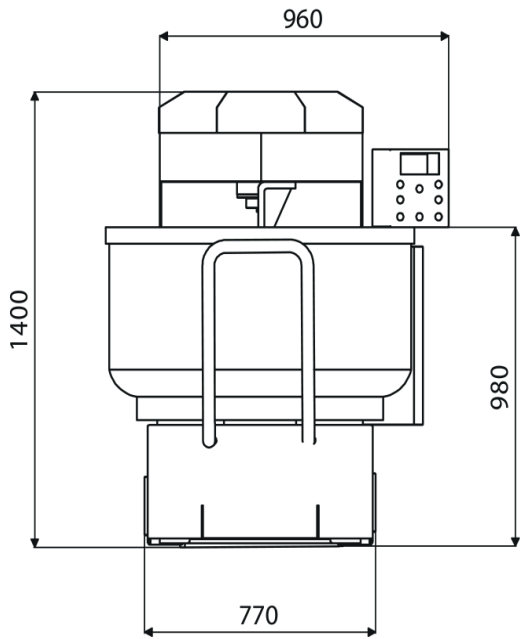
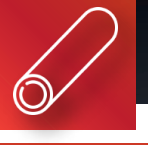

Dough Capacity Capacidad Masa	kg	250	
Flour Capacity Capacidad De Harina	kg	150	
Bowl Dimension Dimension De Caldera	Ø x H (mm)	100 x 1400	
Size Dimension	A x B x H (mm)	1280 x 2200 x 1495	
Energy Energia	kW	17.5	
Bowl Rpm & Spiral Rpm Rpm Caldera & Rpm Espiral	u/min - tr/min	Kazan	Spiral
RPM		18	106 - 212
Weigth - Pesa	kg	1440	

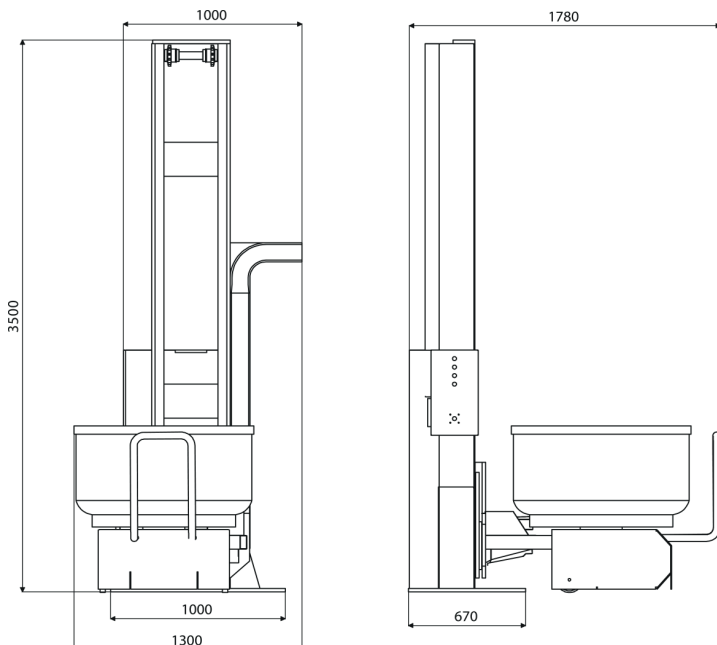

Dimension Dimension	A x B x H (mm)	1000 x 1780 x 3500
Energy Energia	kW	1,1
Capacity Capacidad	Min	100 kg
	Max	250 kg
Weigth Pesa	kg	250 kg



INDUSTRIAL 4.0 bread factory

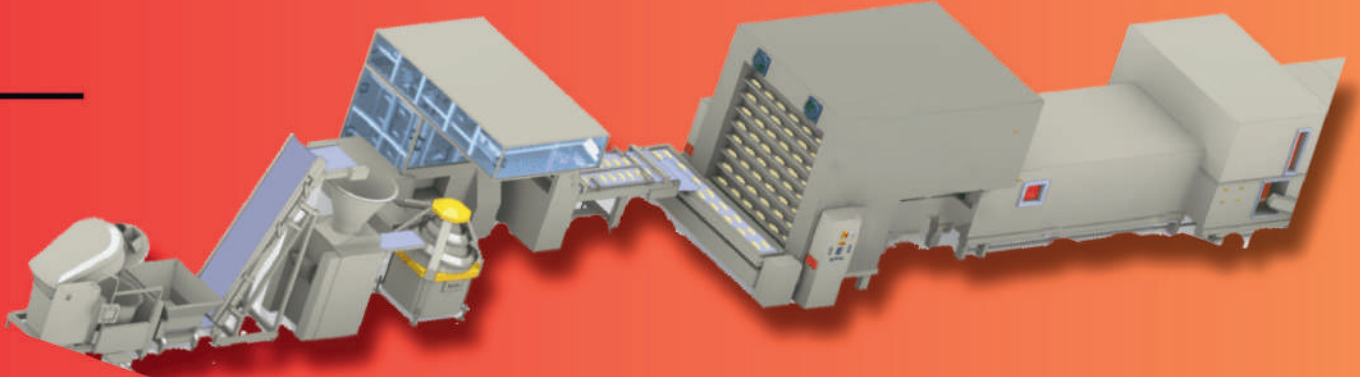

capacity

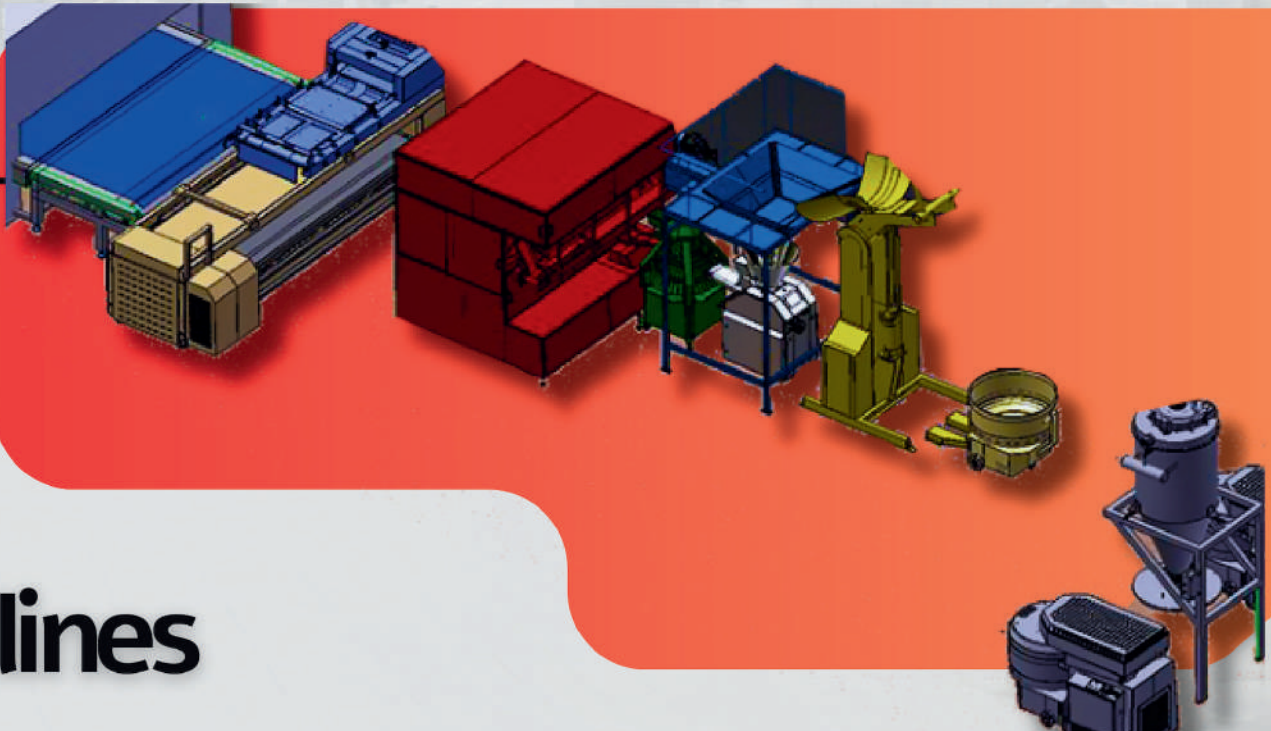

lines

NOTES

öndermak

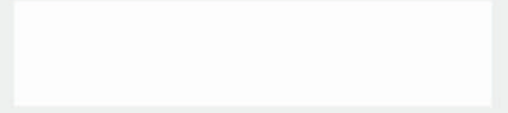

ÖNDERmak®
Eskişehir



Contact Us



PHONE

+90 - 222 236 08 03



ADDRESS

Eskişehir OSB 8. Cadde No:11
PO 26110 - Eskişehir/TURKIYE



MOBILE

+90 - 533 543 07 59



EMAIL

bilgi@ondermak.com.tr

www.undermak.com.tr

